

# **Battery Load Bank**

**PITE3980**

## **User Manual**

P-120921-V2.4

---

# Catalogue

<b>1. INTRODUCTION .....</b>	<b>4</b>
1.1 Accessories.....	4
1.2 Safety Information.....	5
1.3 Operating Precautions .....	6
<b>2. OVERVIEW .....</b>	<b>7</b>
2.1 About PITE3980.....	7
2.2 Display and Keypad.....	8
2.3 Features .....	8
2.4 Specification.....	9
2.5 Measurement Flowchart .....	9
2.6 Definition of Abbreviation .....	10
<b>3. MEASUREMENT PREPARATION.....</b>	<b>10</b>
3.1 Connection.....	11
3.1.1 Check Conditions.....	11
3.1.2 Connection of Cables .....	11
3.1.3 Connect with DAC.....	13
3.1.4 Connect with Computer .....	17
3.2 Disconnection of Cables .....	18
3.3 Power On .....	18
<b>4. MEASUREMENT .....</b>	<b>18</b>
4.1 Battery String Discharge .....	18
4.1.1 Discharge Test .....	19
4.1.2 Discharge for Strings in Parallel Connection.....	22
4.1.3 Continued Discharge .....	23
4.1.4 Parallel Load Test.....	23
4.2 Other Tests .....	25
4.2.1 Assistant Discharge .....	25
4.2.2 External test.....	26
4.2.3 Charge Monitor .....	27
4.3 Data Management.....	28
4.3.1 Read Data Results .....	29
4.3.2 Load to USB drive.....	29
4.3.3 Delete Data Results .....	29
4.3.4 Data Format .....	30
4.4 System Management.....	30
4.4.1 Time Setting.....	30
4.4.2 Parameter Management .....	30
4.4.3 Function Setting.....	33
4.5 Firmware Update .....	34

---

<b>5. SERVICE AND MAINTENANCE.....</b>	<b>34</b>
<b>5.1 Cleaning.....</b>	<b>34</b>
<b>5.2 Storage.....</b>	<b>34</b>
<b>5.3 Trouble-shooting.....</b>	<b>35</b>

---

# 1. INTRODUCTION

This Users Manual gives full information on how to use PITE3980 Battery Load Bank safely and effectively. It applies to all PITE3980 models. Please read the manual carefully so as to obtain maximum performance of the load bank and its accessories.

**Warning:** Read this manual completely before connecting and powering on the load bank to avoid possible damage caused by improper use of this instrument.

## 1.1 Accessories

After receiving the PITE3980 unit, please ensure that no damage occurred during transportation. Upon any damage or failure of operation based on this instrument, please contact your supplier immediately. And make sure you have each items below:

- ◆ PITE3980 main unit (1)
- ◆ Carrying Case (1)
- ◆ Data Acquisition Case (DAC) \*
- ◆ Data Acquisition Leads \*
- ◆ Antenna
- ◆ Data Communication Terminal (1) \*
- ◆ USB-RS232 converter (1) \*
- ◆ USB drive (1)
- ◆ Load Cables (1 black and 1 red)
- ◆ Voltage test lead with two clamps (1)
- ◆ AC Power Cord (1)
- ◆ Users Manual (1)
- ◆ Serial port cable (1,optional)
- ◆ Current clamp (1, optional)
- ◆ Grounding line (1)

**NOTE:**

- 1) Amount of Accessories marked with “\*” may vary based on different PITE3980 models. Please confirm with your supplier before each order.
- 2) DAC (Data Acquisition Case) is optional for data logging of each cell in PITE3980 series load banks, amount of DAC and DAC serial cables may vary in different models. In some basic load unit, there is no DAC and relevant cables. For detailed connection, please refer to **3.1.3 Connect with DAC**.



 <p>Red Load Cable</p>	 <p>Black Load Cable</p>	 <p>Voltage test lead with two clamps</p>
 <p>DAC serial cable, 7-lead (Optional with DAC)</p>	 <p>DAC serial cable, 3-lead (Optional with DAC)</p>	 <p>Antenna (for main body)</p>
 <p>User Manual</p>	 <p>Grounding line</p>	 <p>USB drive</p>
 <p>Current clamp (optional )</p>	 <p>AC220 Power Cord</p>	 <p>DAC (Optional)</p>

**\*NOTE:** For convenient transportation, models with size of XL or bigger will be made with rolling wheel at main unit bottom and packed with wooden case instead of carrying case. For detailed configuration, please refer to **2.4 Specification**.

## 1.2 Safety Information

When you read this user manual, please carefully observe all warnings, precautions and instructions for effective operation of PITE3980.

**WARNING:** Servicing described in this manual is to be done only by qualified personnel. To avoid electrical shock, do not service the instrument unless you are qualified enough under LB's instruction.

 <p><b>DANGER</b></p>	<p>Safety testing has been done on this instrument thoroughly before shipment. However, mishandling during use could result in injury or other bad consequences, as well as damage to the instrument. Make sure that you understand the instructions and</p>
----------------------------------------------------------------------------------------------------------	--------------------------------------------------------------------------------------------------------------------------------------------------------------------------------------------------------------------------------------------------------------

	precautions in the manual before use. We disclaim any responsibility for accidents or injuries not resulted directly from instrument defects.
--	-----------------------------------------------------------------------------------------------------------------------------------------------

### Safety Symbols

Description of symbols used in this manual.

 <b>WARNING</b>	Indicates correct operation to prevent a significant hazard that could result in serious injury or other bad consequences to users or the product.
<b>NOTE</b>	Indicates advisory items related to performance or correct operation of the instrument.

## 1.3 Operating Precautions

### WARNING:

- ◆ The electrical voltage and current used in battery testing is potentially lethal.
- ◆ Ensure that the AC supply is isolated and any battery under test is disconnected before attempting any cleaning or maintenance of PITE3980.
- ◆ Do not connect or disconnect any of the cables unless the circuit breaker is turned off.
- ◆ Connection and disconnection procedures are extremely important. Be sure to follow the instructions faithfully.
- ◆ Do not touch conducting parts of the load cables or the voltage cables when they are connected to PITE3980.
- ◆ Explosion risk when using PITE3980 (all models)
- ◆ When a lead acid battery is charged or discharged i.e. when there is a current flow through the battery it is always a risk that the battery can explode.
- ◆ For new open (vented) batteries the risk is medium to low but in old VRLA (sealed) batteries the risk is medium to high.
- ◆ If there is a bad connection inside the battery and there is a current flow - the connection will burn off and there will be an arc, which will ignite the oxyhydrogen gas in the battery.
- ◆ To minimize the risk for personnel injuries: Always place PITE3980 as far away from the battery as possible - use long load cables and do not stand close to a battery during charge or discharge.
- ◆ Too high discharge current applied on a battery can cause the battery to explode or get over-heated. And may also over-wear the batteries. Be sure to not set too high current.
- ◆ If the external current measurement is interrupted or giving false values during the test, the current will rise to a higher level than the set value before the test is shut down. If the battery is too small for this current or in a bad condition - it may explode.
- ◆ If you see any spark from batteries, testing cables or PITE3980 main body, please switch off the unit and disconnect all cables for further inspection.

### IMPORTANT:

To use PITE3980 efficiently and avoid electrical shock, fire or any damage to the PITE3980

---

or its accessories, please do read these precautions carefully before using PITE3980:

- ◆ Except as explained in this manual, do not attempt to service this equipment yourself.
- ◆ To avoid frequency interference, please do not run two PITE3980 simultaneously in the same location within 100 meters if it is not parallel connection. If you really have to, please contact LB for presetting.
- ◆ Before use, check to see if the nominal voltage ranges on the PITE3980 matches the batteries that you are going to test. Do not apply PITE3980 of lower voltage in higher voltage. For example, if PITE3980 nominal voltage is 48V, do not connect the unit with batteries of 220V. Otherwise, some parts inside PITE3980 main body may get damaged.
- ◆ Do not operate the PITE3980 around explosive gas or vapor.
- ◆ Use only insulated load cables and test leads supplied with the load bank.
- ◆ Before use, please inspect the load bank, load cables, test leads and accessories for mechanical damage and replace them when they are damaged. Pay special attention to the insulation surrounding the connectors.
- ◆ If you have more than one PITE3980, please use them separately, do not mix them up. Their accessories may not compromise with each other.
- ◆ Remove all clamps, test leads and accessories that are not in use.
- ◆ Make sure that the mains voltage and frequency fit the local AC power supply. Do not apply the unit to voltages that are above the rated mains of the instrument.
- ◆ Ensure that the equipment is provided with adequate ventilation. Do not block equipment ventilation openings.
- ◆ Proper installation is essential to the correct functioning of your analyzing software CD. If you have any questions about installation, please contact your supplier for assistance.
- ◆ After discharging batteries for some hours, please keep the main body powered on for at least 10 minutes. This will help cool down the resistors and other electronics inside the main body and prevent it from over wearing.
- ◆ If you need to discharge the next battery string right after the first string, please wait for at least 30 minutes to let the unit cool down also.

## **2. OVERVIEW**

### **2.1 About PITE3980**

PITE3980 series Battery Load Bank are for battery discharge experiment, capacity test, battery string maintenance, project checkup and acceptance, and DC power load test. For battery maintenance, it is periodic examination (e.g. once a year). It is used to judge the capacity of cells to see whether cells are weak to remove or renew. Users judge its capacity by the way of discharge in one string or more strings.

The wireless communication technology enables it continuously monitor and display the real-time discharging process of all individual cells via the monitoring terminal.

The measurement data can be read on the instrument screen directly. It can also be uploaded to a personal computer via a USB driver. With the analyzing software, you could

have an all-rounded analyzing for the testing result and status of batteries.

## 2.2 Display and Keypad

The 6-button keypad enables you for quick navigation through the screen display or menu.

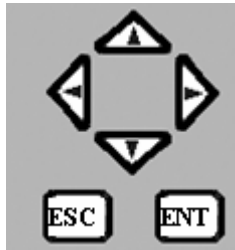

Fig.2.2. Keys Operation

Keys	Functions
▼ ▲	Move up and down to highlight the selecting options
◀ ▶	1. Change the numbers 2. Move back and forth to highlight the selecting options
ENT	Confirm the selection or number input
ESC	Return to the previous menu

## 2.3 Features

- ◆ Rugged, compact and portable unit with carrying case
- ◆ Wireless communication for convenient discharge monitoring in PC
- ◆ It sets 4 conditions for auto shut-down of discharge:  
discharge time, discharged capacity, cell cut-off voltage and total cut-off voltage
- ◆ Continued discharge available when certain cells voltage reach cut-off value
- ◆ Parallel connection of two units for mass discharge
- ◆ Real-time display of voltage for each cell
- ◆ Accurate data results and vivid waveforms
- ◆ Powerful management system for data analyzing
- ◆ Auto sorting for lag-out batteries during discharging
- ◆ Optional AC & DC power supply modes for different needs
- ◆ Integrated functions for displaying, controlling and discharging
- ◆ Safe circuits avoids damage to battery when testing
- ◆ Direct USB drive for convenient data transfer to PC
- ◆ Warning info, dynamic discharge and static discharge data auto-saving
- ◆ It covers different types of batteries for a wide range of discharging like 24V, 48V, 110V, 220V and 380V in different models

## 2.4 Specification



Power Supply	AC 220V/110V or DC (from battery, optional), 50/60Hz		
Discharging Current	Accuracy: 1%    Resolution: 0.1A or 0.5%		
Discharge voltage range	48V: 10-55.2V    110V: 10V-126.5V* 220V: 10-253V    380V: 10-437V		
Voltage Accuracy	0.5%	Sampling Interval	5s--1min
LCD Display	128*64 pixel	Communication	USB
Temperature	0°C~40°C    5%~90% Relative humidity		
CE marking	EMC standard: EN55022:2006 EN55024:1998+A1:2001+A2:2003 EN61000-3-2: 2006 EN61000-3-3:1995+A1:2001+A2:2005		
Dimension (main unit)*	400*177*280 mm (Size: S) 520*202*355 mm (Size: M) 555*225*435 mm (Size: L) 603*400*740 mm (Size: XL)		
Weight (main unit)*	11kg(S)    16kg(M)    21Kg (L)    43Kg (XL)		



### NOTE\*:

- 1). In some countries, 110VDC is replaced by 125VDC with range of 10-143V, and 220V is replaced by 240V (10-288V).
- 2). Dimension and weight depend on different models; more customized models may differ in some aspects.

## 2.5 Measurement Flowchart

The measurement workflow is described as below

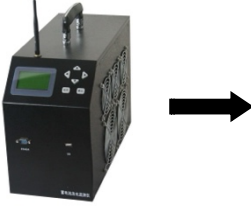
<p>Measurement Preparation</p> 	<ol style="list-style-type: none"> <li>1. Wear necessary protective clothing</li> <li>2. Connect the AC power cord (if power supply is from AC)</li> <li>3. Connect the testing leads</li> <li>4. Turn the power on</li> </ol>
<p>Start Measurement</p> 	<ol style="list-style-type: none"> <li>1. Select measuring mode</li> <li>2. Read displaying results</li> </ol>

<p>Ending of Measurement</p> 	<ol style="list-style-type: none"> <li>1. Disconnect the test leads from the subject of measurement</li> <li>2. Turn off the power</li> <li>3. Disconnect the power cord</li> </ol>
<p>Data uploading</p>  <p>Measurement of data</p> 	<ol style="list-style-type: none"> <li>1. Use a USB drive to load the testing data and transfer the data to PC</li> <li>2. Data management on PC</li> </ol>

**WARNING:** There are high voltage and current in cells and the load bank components. Only qualified personnel can perform all the measuring procedure. Pay special attention to precautions of electrical and chemical safety when removing cells, installing cells, connecting leads and making measurements.

## 2.6 Definition of Abbreviation

Below are the definitions of abbreviated words used in PITE3980 software menu:

Abbreviation	Full name	Abbreviation	Full name
avg	average	I	current
DIS	discharge	Paral	Parallel
C	capacity	param	parameter
calib	calibration	strg/stg	string
Case	acquisition case	syst	system
CHG	charge	T	time
comm	communication	tot	total
EX	exit	U	voltage

## 3. MEASUREMENT PREPARATION

This section describes how to connect all the testing leads and cables in correct way and sequence. It is very important for the whole process of operation. For the safety of equipments and operators, please read it carefully.

## 3.1 Connection

### 3.1.1 Check Conditions

Before any connection, make sure that:

- 1). The battery strings are not working and cut off from power supply.
- 2). There is enough space for testing. Do not test the unit around explosive gas or vapor.
- 3). The nominal voltage of the load bank matches that of the battery strings.

### 3.1.2 Connection of Cables

**IMPORTANT:** Power supply and control on-off (circuit breaker) should be turned off before all wire connections. To ensure the safety, please turn on the control on-off **ONLY** when all the other connections are finished.

All switches and cable sockets are at the back of the main unit. Please see below for the back panel of PITE3980.

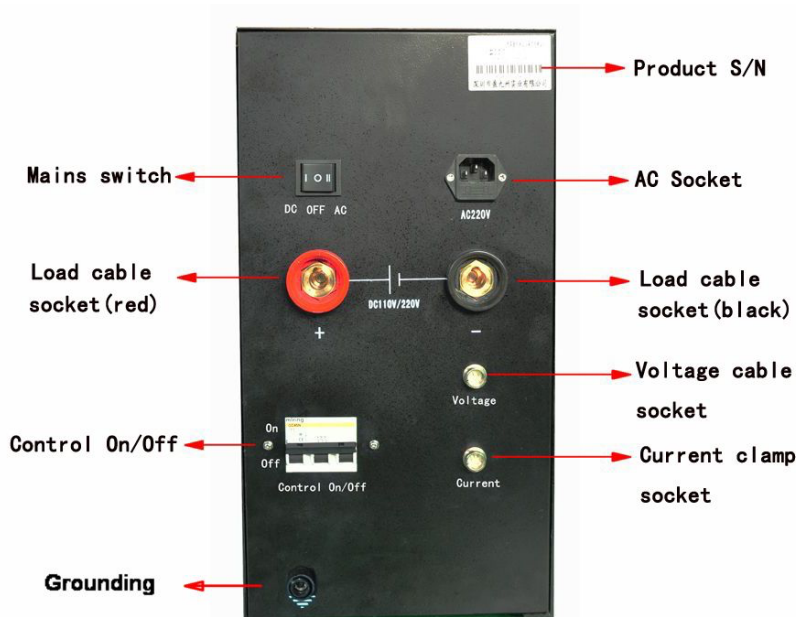

Fig 3.1.2

#### A. Connection of load cables

- Connect one end (round socket) of the black load cable with the black port of the load bank and the other end (with clamp) with the negative pole of battery string.
- Connect one end of the red load cable with the red port of the load bank and the other end with the positive pole of battery string.

**⚠WARNING:** Make sure they are correctly and tightly connected to avoid electrical fire and short circuit. The black and red load cables should be firstly connected with load bank main unit with power off, and then with batteries. If you firstly connect them with batteries and the other two ends accidentally get connected with each other, there will be return circuit. Thus load cables and their clamps may get burned.

In the same way, after the testing is done, please first turn off the power, disconnect the load cables from batteries and then disconnect them from PITE3980 main unit.



Fig. 3.1.2.A1

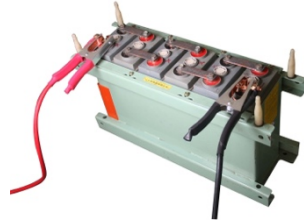

Fig. 3.1.2.A2



Fig. 3.1.2.C

**B. Connection of voltage testing lead**

Connect one end (round connector) of the voltage testing lead to the voltage socket of the PITE3980, and the other two clamps with two poles of battery string. The red clamp is connected with the positive pole and the black with the negative of battery string.

**C.** Connect the antenna to the antenna socket of the load bank like Fig. 3.1.2.C. LB only has one type of antenna for main unit, DAC and communication terminal.

**D.** When power supply is from AC, connect the load bank to an appropriate AC power source with the AC power cord. And turn the power switch at the back of load bank to AC 220 (or 110V mains). When power supply is from batteries, turn the mains switch to DC. In that case, power will be supplied via the two load cables.

**E.** In the following 3 auxiliary testing functions, you will need a current clamp:

1) External discharge.

In this function, PITE3980 only serves the function to display the voltage (by DAC) and current values of external load.

If you do not need to test current value of external load, current clamp is not needed.

2) Reparation discharge (assistant discharge)

For example, if external loads discharge 10Amps from the batteries and but your target is to discharge 25Amps, you could use PITE3980 reparation discharge to handle the rest 15Amps.

A current clamp is needed to monitor the external current value. If external value is changed (e.g. 13Amps), reparation discharge value will change (12Amps) accordingly so as to make total discharge current (25Amps) unchanged.

Current clamp range is accordant with external load.

3) Charge monitor

PITE3980 also only serves the function to display the voltage (by DAC) and current values as the batteries are charged. If you do not need to monitor current value or you have other way to monitor current value, then optional current clamp not needed.

So no matter which way it takes, current clamp range should be accordant with external loads or chargers. For details, please refer to **4.2 Other Test**.

**⚠️WARNING:** Make sure the black load cable is connected to the negative pole, and the red one to the positive, otherwise it may cause significant damage to the load bank.

---

**Other way of load cable connection:**

In some high power model of load bank, clamp of load cable is bigger and harder to open. Therefore, in these models of load bank package, the clamps are separated from cables like Fig 3.1.2.1. For different situation, you could use load cable connected directly with battery posts like Fig. 3.1.2.2. Or you could fix the clamp on load cable and connect with battery like Fig 3.1.2.3.



Fig 3.1.2.1

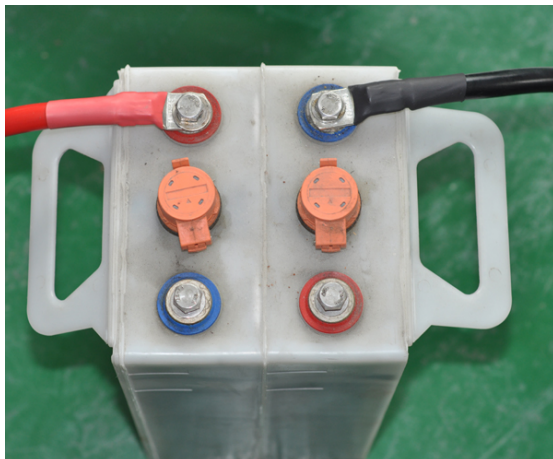

Fig 3.1.2.2

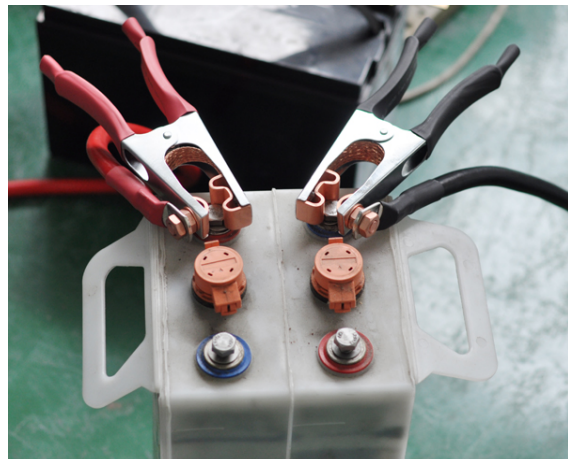

Fig. 3.1.2.3

**3.1.3 Connect with DAC**

**Reminder:** Below are introduction of DAC and instruction for its connection with batteries. This info is for the new DAC with insulation-protected case only. For introduction and connection ways of old model (black metal case) of DAC, please refer to previous version.

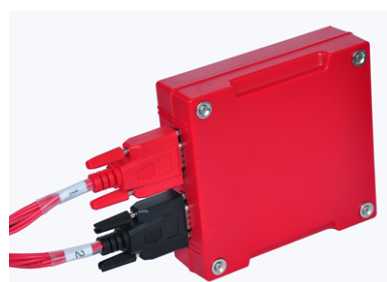

Fig.3.1.3.1 DAC

Fig. 3.1.3.2 Magnetic bolts for instant Attachment to metal bars or cases

**About DAC**

The DAC is optional to PITE3980. It is used for data logging of voltage for each cell. With built-in antenna, it could have wireless communication with PITE3980 main body and PC software.

If your model of PITE3980 comes with DAC and relevant serial cables, please see below for instruction. If there is no DAC for your model, voltage of each cell will not display either in the main unit screen or the PC software during discharge.

Each DAC has 2 serial ports for connection with DAC serial cables. These 2 ports are labeled with 1 and 2 which are connected with red (#1) and black (#2) connectors of DAC cable. They are for connecting with different series of batteries in a string. For detailed way of connection, please refer to the text below.



**About DAC leads**

PITE3980 also has two kinds of data acquisition leads 7-lead and 3-lead

All standard models of PITE3980 battery load bank could test batteries of 2V, 6V and 12V. For different battery types, we have two kinds of data acquisition cable: 7-lead and 3-lead. Please use the 7-lead cable (Fig.3.1.3.3) for testing 2V batteries. And use the 3-lead cable (Fig.3.1.3.4) for 6V or 12V batteries. In these PITE3980 units, both 7-lead and 3-lead use the same DAC.

**NOTE:** In optional models of PITE3980 battery load bank which test 1.2V, ways of DAC connection with battery are same with that of 2V batteries.

Please see pictures below for further illustration of data acquisition leads:

 <p style="text-align: center;">Fig.3.1.3.3</p>	 <p style="text-align: center;">Fig.3.1.3.4</p>
<p>7-lead, 1 black and 6 red                  For testing 2V batteries                  One cable is connected with 6 cells                  One DAC is connected with 12 cells</p>	<p>3-lead, 1 black and 2 red                  For testing 6V or 12V                  One cable is connected with 2 cells                  Once DAC is connected with 4 cells</p>



**NOTE:**

- a) All PITE3980 models have the same type of DAC (may be different in amount). However, all DACs have been programmed with different serial numbers to match specific PITE3980 unit. Therefore, for DAC connection with batteries, use them in the order of DAC 1, DAC 2 and so forth.
- b) If you only need the PITE3980 as a load without voltage logging for each cell, then

it is no need to connect DAC or relevant cables. You will only need to set the total cutoff voltage, discharge time and capacity. In that case, cell number should be set as 0. For detailed settings, please check **4.1.1 Discharge Test**.

**Way of connection**

**1). Connection of DAC and leads are as below:**

 <p style="text-align: center;">Fig.3.1.3.4</p>	 <p style="text-align: center;">Fig.3.1.3.5</p>
<p>Connection with 2 serial cables of 7-lead</p>	<p>Connection with 2 serial cables of 3-lead</p>

**2). Connection of DAC leads and batteries**

Below are correct ways of connections for DAC leads with different batteries

**A. Connections for 3-lead cable will be as below:**

Make sure that DACs are always connected with battery string beginning from negative pole, no matter the whole string begins from the negative pole or possible pole.

Hereafter, "0" below indicates the black lead which is connected with negative pole of batteries. Every DAC lead is labeled with serial numbers (0, 1, 2 ...) below. They have nothing to do with serial numbers marked on the batteries. However, DAC leads should be connected with batteries in sequences of 0, 1, 2 and so forth.

**NOTE :** 1# below indicates serial port labeled with "1" on DAC. 2# means "2" labeled on DAC. This is same to all the other ways of DAC connection described below.

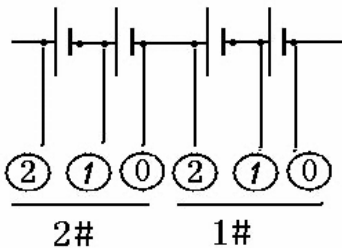

Fig.3.1.3.A

**B. Connections for 7-lead cable will be as below:**

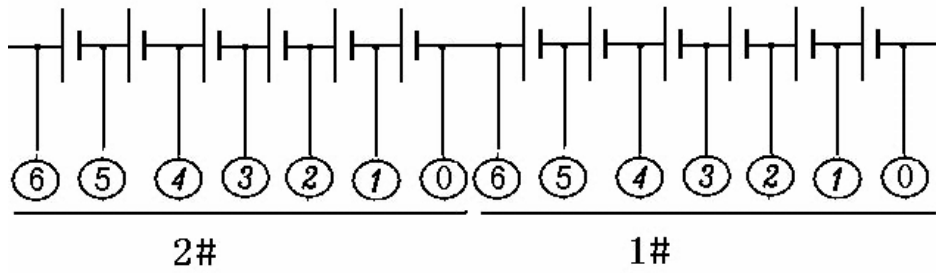

Fig.3.1.3.B

**C.** If there is only one DAC and cell numbers are less than what one DAC can measure, we have two situations:

- 1). If you only need one DAC serial cable for all cells connection, then just use one serial cable (connected with serial port 1#). See examples in Fig.3.1.3.C1 and Fig.3.1.3.C3.
- 2). If you need 2 serial cables for cell connection but have spare DAC leads, then connect all of the spare leads (on port 2#) with the last cell. See examples Fig.3.1.3.C2 and Fig.3.1.3.C4.

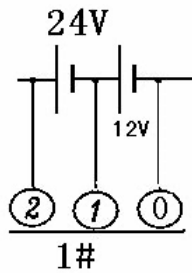

Fig.3.1.3.C1, cell type: 12V

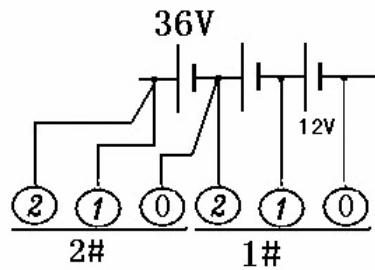

Fig.3.1.3.C2, cell type: 12V

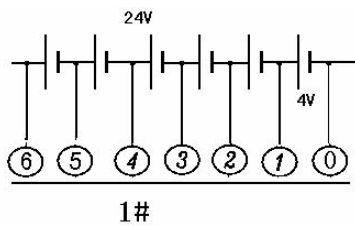

Fig.3.1.3.C3, cell type: 4V

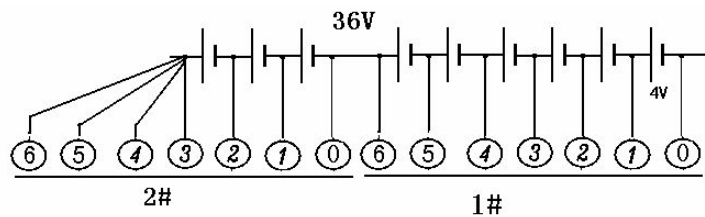

Fig.3.1.3.C4, cell type: 4V

**D.** For more than one DACs (e.g. cell type is 12V), connection is like below:

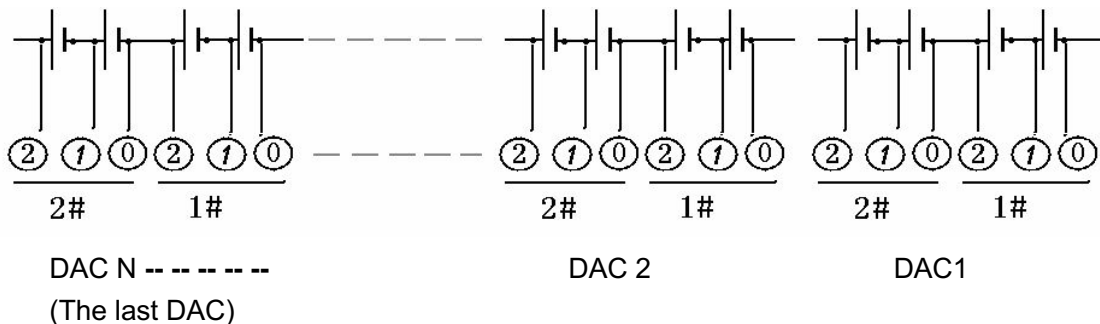

Fig. 3.1.3.D

**E.** If there are more than one DAC and with spare leads (the last DAC), connection of the

last DAC will be: the last testing lead M# (labeled with highest serial number) will be connected with positive pole of the last (N#) cell; and testing lead (M-1) # will be connected with positive pole of (N-1) # cell, so and so forth until all the spare leads are well connected. Cell type is 12V in the example below:

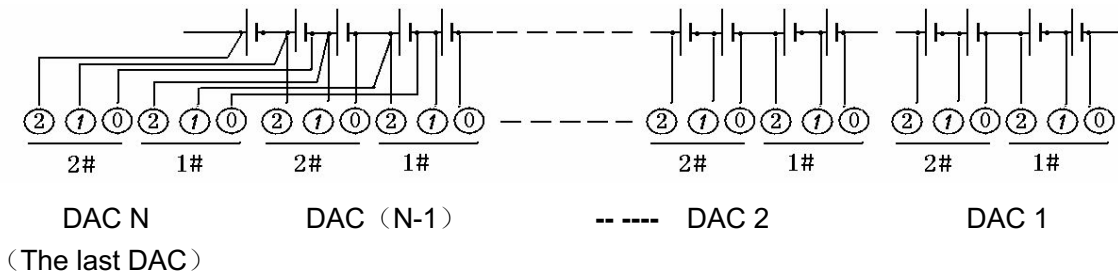

Fig. 3.1.3.E

DAC is powered by batteries that are connected via different DAC leads. When you see the indicating light on DAC blinks, the DAC gets full power supply then. If you do not see indicating light blinks when connecting the first DAC lead, continue to finish connection with other leads.

### 3.1.4 Connect with Computer

With the LB DataView Software, you could have a real-time monitoring during the whole process of battery discharging and even battery charging. Flowchart of discharge monitor is as below:

1. Install the software driver for USB-Rs232 converter in your PC. For installation instruction, please check its manual separately.
2. Connect the USB-Rs232 converter with PC and remember the com port number.
3. Connect data communication terminal with USB-Rs232 converter and switch on the terminal.
4. Start discharging, test com port and start online monitor. For software operation on PC, please refer to **6.3.1 Real-time Monitor**.



Fig 3.1.4 connection of com terminal with PC

---

## 3.2 Disconnection of Cables

After battery discharge is finished, please keep the main body powered on for at least 10 minutes. This will help cool down the resistors and other electronics inside the main body and prevent it from over wearing. This is pretty important to use the load bank effectively.

To ensure security of equipment and operator, please disconnect all cables in the following sequence:

- 1) Turn off the power switch
- 2) Turn off the control on/off
- 3) Disconnect power cord from mains
- 4) Disconnect load cables first from batteries and then from PITE3980. The two load cables should be removed one after one. This is important for security.
- 5) Disconnect the voltage cable first from battery and then from PITE3980 load bank.
- 6) Disconnect the serial cable for parallel connect (if any).
- 7) Remove current clamp (if any) from PITE3980.

## 3.3 Power On

After all cables are well connected, PITE3980 is ready for operation. Turn on power switch and control on/off on PITE3980, the screen will display info of configuration and software version like below:

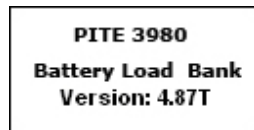

Fig. 3.3

**NOTE:** Above figure is only for reference. Specification and version information will differ based on different configuration.

The following main menu will show after initialization of about 10 seconds:

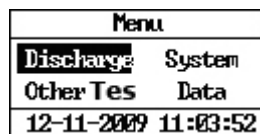

Fig.3.3.1

## 4. MEASUREMENT

### 4.1 Battery String Discharge

Press the keys  $\uparrow/\downarrow$  to highlight **[Discharge]** and press **[ENT]** to the following step

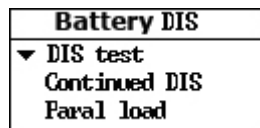

Fig.4.1

#### 4.1.1 Discharge Test

This is basic function for battery discharge by PITE3980; it is different from external discharge by other load. With optional DAC and LB DataView software, you could have a real-time monitoring for discharge in your PC. For detailed way of operation, please refer to **6.3.1 Real-time Monitor.**

To start operation in PITE3980 main unit, select **[DIS test]** under the menu **[Battery DIS]** and press **ENT**:

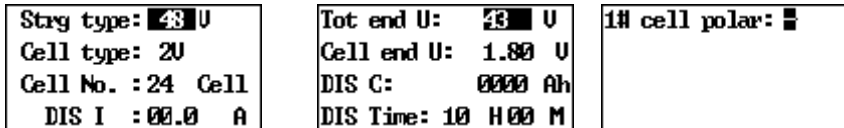

Fig.4.1.1

In the menu **[DIS test]**, press ←/→ arrow keys for number setting, use ↑ and ↓ to move up and down.

There are 9 options under **[DIS test]** including: **[Strg type]** (nominal voltage, optional among 24V, 48V, 110V, 220V and 380V. Based on different PITE3980 models, you have different options), **[Cell type]** (1.2V, 2V, 6V or 12V), **[Cell No.]** (Indicates tested cells quantity. If there is no connection with DAC, set is as 0), **[DIS I]** (indicates working current), **[Tot end U]** (indicates the total cut-off/threshold voltage for the battery string), **[Cell end U]** (indicates the cut-off voltage for the individual cell), **[DIS C]** (indicates the discharged capacity of battery string), **[DIS Time]** (indicates the duration for this test.), **[#1 cell polar]** (indicates the beginning polarity of first cell in the whole string),

#### About first cell polarity

About first cell polarity setting, please see below:

As we mentioned above, DAC is always connected with battery string beginning from negative pole, no matter the whole string begins from the negative pole or possible pole.

So for DAC connection in different countries, there are 2 situations as below:

- 1) If polarity of first cell in string is negative (-), then you should select negative (-) in menu. And NO.1 DAC is connected from the first cell.
- 2) If polarity of first cell in string is positive (+), then the last polarity of the string will be negative (-). In that case, you should connect the DAC 1 with string, beginning from the last cell. Cell polar is set as positive (+). Then cell No. 1 is the actual reading shown on the PITE3980 LCD display and so forth

If DAC connection is correct but setting of first cell polarity is incorrect, voltage value displayed in PITE3980 LCD screen and PC software will be reversed. In another word, voltage value of first cell will become value of the last cell, second will become second last and so forth.

#### Four conditions for discharge auto-stop:

They are: Total end voltage, cell end voltage, discharged capacity and discharge time.  
 The discharge process will stop once any one of these 4 conditions reaches its setting value (threshold).

**Setting of cutoff voltage:**

Setting of cutoff voltage is for the protection of cell. Correct setting of cutoff voltage value will prevent the cell from over discharge and thus avoid damage to the cell. Following settings are for your reference:

1.2V cell—Cutoff discharge voltage: 1.08V;

2V cell---Cutoff discharge voltage: 1.8 V;

12V cell---Cutoff discharge voltage: 10.8 V;

After setting for all parameters, press **ENT** to continue:

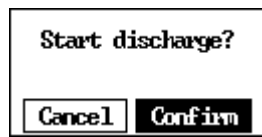

Fig.4.1.1.1

Select **[Confirm]** and press **ENT** to execute the operation. To use LB software for discharge monitor, you have to test com port after you see the following screen.

It will need 1 minute before the discharge begins as screens below:

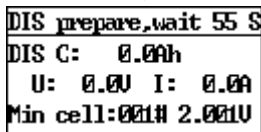

Fig.4.1.1.2

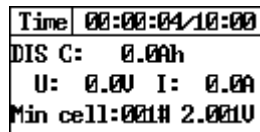

Fig.4.1.1.3

**NOTE:** If the internal memory space is not enough, the following screen will pop up:

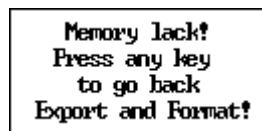

Fig.4.1.1.4

Press any key to exit, go back to data management menu, download the previous records to a USB drive, and delete the data to continue discharging process.

After entering discharge screen, it needs 1 minute to check each cell voltage before discharge starts. Thus testing personnel knows the situation of the string. After discharge ends, there is 1 minute left to test the recovering of voltage

In discharge screen (Fig.4.1.1.3), **[DIS C]** indicates string capacity discharged from batteries. **[U]** indicates total voltage of string. **[I]** indicates actual discharged current. **[Min cell]** indicates the cell with lowest voltage during discharging. In example of Fig.4.1.1.3, No. 1 cell has lowest voltage, 2.001V.

**NOTE:** Descriptions in this part assume that your PITE3980 is operated with DAC. If you do not have data logger (DAC) for your PITE3980 model, voltage of each cell will not display.

In the screen of Fig.4.1.1.3, you could press arrow key ↓ to check voltage value of each cell as below. These values will keep changing as discharge goes and will stop until one of the setting conditions meets its threshold.

001#2.001U	005#2.005U
002#2.002U	006#2.006U
003#2.003U	007#2.007U
004#2.004U	008#2.008U

Fig.4.1.1.5

Press ↑/↓ arrow keys to view voltage of all cells with serial numbers. After viewing all cells voltages, press ↓ to view the 6 cells with lowest voltages and their cell number as below:

Lowest U cell	
001#2.001U	003#2.003U
002#2.002U	014#2.003U
013#2.002U	004#2.004U

Fig.4.1.1.6

Continue to press ↑/↓ arrow keys; you will see your predefined parameter as below

Param setting
Strg type:48U
Cell type:2U
Cell No. :24Cell

Fig.4.1.1.7

All the above screens could be paged up and down by pressing ↑/↓ arrow keys. DAC could be replaced upon communication problem during discharging. When certain DAC has communication problem during discharging, you will see indicating screen like below:

cell case err! Press any key DIS
-------------------------------------

Fig.4.1.1.8

Press ↓ to the next page as below:

Comm err case No.	
001#	

Fig.4.1.1.9

When there is DAC error, press ← to replace DAC:

13 # replace 1#
-----------------

Fig.4.1.1.10

To replace the new one, please unplug the defective DAC from its testing leads and plug the new DAC. Select the backup DAC (e.g. 03#, already programmed in LB factory) on screen

---

and error case. Then confirm the replacement,  
All DACs have been programmed in LB factory with different serial numbers. If you replace No. 1 with No. 3 case, then No. 3 will physically become No. 1 case in the program. Please do remember the change.

#### 4.1.2 Discharge for Strings in Parallel Connection

If you have battery strings of same nominal voltage in parallel connection, and you want to discharge these strings together, then you could use this function. Maximally PITE3980 supports 5 strings in parallel connection, discharged by one PITE3980 load bank.

##### Preparation:

- 1) Make sure that all cells are of the same type (like 2V 1000Ah), and all strings are of same nominal voltage like 48V battery system.
- 2) And if you have DAC, make sure that all DACs are well grouped as String 1 (DAC 1, 2...), String 2 (DAC 1, 2...) and so forth. Generally the setting of DAC number is done well in LB's factory before shipment to our customers'.
- 3) Connect the load cable and voltage test leads with two ends of any string.
- 4) Connect the DACs with each battery string in the sequence of String 1 (DAC 1, 2...), String 2 (DAC 1, 2...) and so forth.

##### Operation:

After the above wire connection, please do the setting as per **4.4.3 Function Setting**. Then go to **[DIS test]** for parameter setting as Fig.4.1.2.2. Setting will be in two steps as below:

##### 1) Setting of first battery string:

**[String]** indicates the total amount of strings that are in parallel connection. If there are 2 strings, set it as 2. Then set **[String No.]** as 1, this indicates the first string. After these two steps, all setting will be same as that of single string discharge described in **4.1.1 Discharge Test**. Setting of discharge current should be total current values of all strings.

Setting of string cut off voltage, discharge current, cell cut off voltage and so on will be based on the first string.

##### 2) Setting of other battery strings

After the above step, move the upper arrow key to page up. Change **[String No.]** as 2 and set its cell amount accordingly in **[Cel logged]**, e.g. Fig.4.1.2.3.

If there are more strings, move the upper arrow key to change **[String No.]** as 3 and set its cell amount accordingly. Do it in the same way for all the other strings.

After the above setting, press the button **ENT** to start discharging.

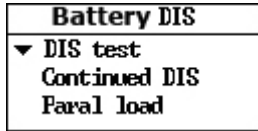

Fig.4.1.2.1

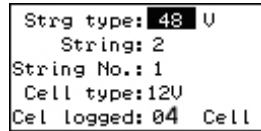

Fig.4.1.2.2

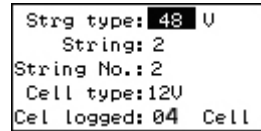

Fig.4.1.2.3

**NOTE:**

During battery discharge, current value of each string may vary more or less depending on actual capacity of each battery. To test real battery capacity by battery discharge, you are suggested to discharge the batteries string by string.

**4.1.3 Continued Discharge**

If you still want to continue the discharge when the previous discharge process is abnormally stopped manually, or some of the cells have been weak and reached their voltage threshold (not because time is up or discharged capacity reaches its setting value), then you could use continued discharge function in the menu **[Battery DIS]**. Select **[Continued DIS]** as below:

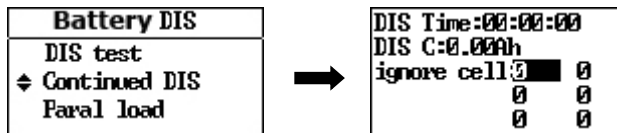

Fig. 4.1.3.1

Press ↓ arrow key to page down as below:

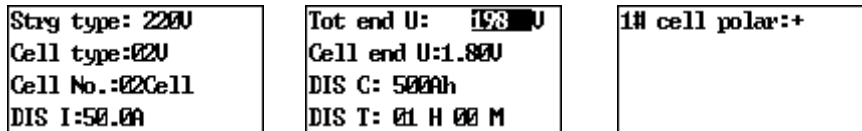

Fig. 4.1.3.2

**Parameter setting:**

Press “←/→” arrow keys to lower the value of **[Tot end U]** if previous test was stopped due to abnormal cells. In **[ignore cell]**, select the cells that have problem in the previous test. In another word, these cells have reached the cut off voltage before time is up. Maximally you could ignore 6 cells including cells that almost reach cut off voltage.

**NOTE:**

- 1) In continued discharge, cells with low voltage (ignored cells) will still keep discharging until other conditions (e.g. total end voltage) reach their setting value. Therefore, please mind the time to avoid over-discharging of the ignored cells.
- 2) If there is no DAC, it is no need to input “ignore cell”.

After the setting, press **[ENT]** to continue the discharge test.

**4.1.4 Parallel Load Test**

If the required discharge current is higher than rated value (e.g.300A) of the load bank, an extra load will be necessary to extend the actual current. For example, when discharge of

550A is required, you will need two load banks (2\*300A) to discharge in parallel. After parallel connection, the maximum discharge current will be 600A. One unit will be Chief Unit and another one will be the Assistant Unit.

**NOTE:** Only load banks with same nominal voltage could be used in parallel connection. For example, 48V 100A and 48V 200A could use operation of parallel connection. 48V 100A and 110V 100A could not.

To start this function, firstly connect all the testing cables (except DACs) between the batteries and the second unit (assistant unit) like the previous one. And connect the two units with a serial cable as below:

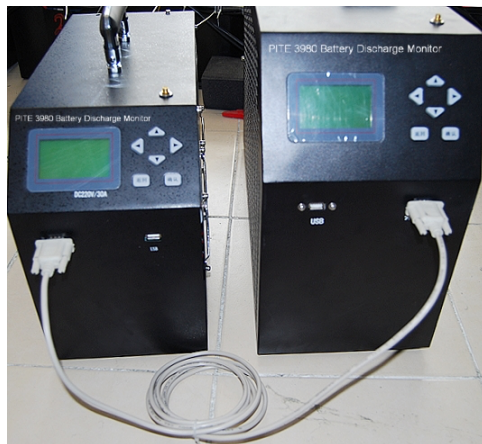

Fig.4.1.4.1

In parallel load test, please confirm these things first:

- A. The two units have the same nominal voltage, e.g. 220V 50A and 220V 100A (max current in parallel connection: 150A).
- B. For all PITE3980 standard configurations, the serial cable is optional. Please confirm with LB sales representative if you need it.

Please only switch on the assistant unit, no need to set parameter there. All parameter settings will be done on the chief unit.

In chief unit screen, press ↑/↓ to select **[DIS test]** under **[Battery DIS]** as below:

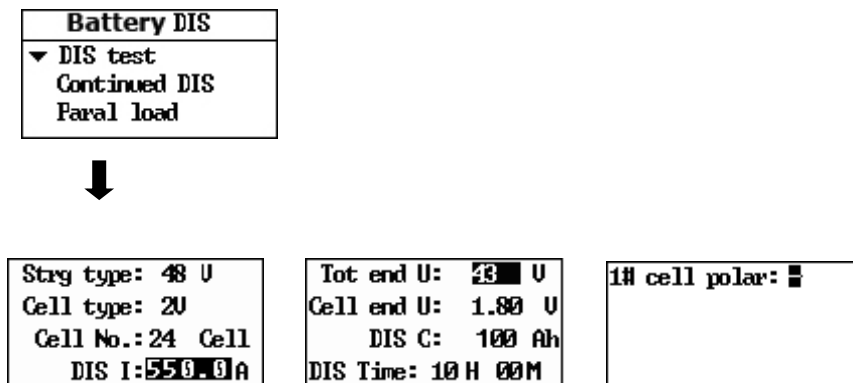

Fig.4.1.4.2

**NOTE:** In these parameters setting, discharge current should be set as required current

550A (in above example). Only when setting value is higher than rated current can parallel connection succeeds. Other parameter settings are the same as that of **[DIS test]** previously introduced in **4.1.1 Discharge Test**.

After above settings, press **ENT** to continue. The displaying screens and the operation steps are the same as **[DIS test]**.

## 4.2 Other Tests

This part will introduce other supplemental ways of discharge including assistant discharge test, External discharge test and Charge Monitor under **[Other Tes]**:

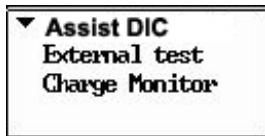

Fig. 4.2

### 4.2.1 Assistant Discharge

“Assistant discharge” is like auxiliary discharge to external discharge (see **4.2.2**). This function is used when batteries are online connecting with other loads. You will need a current clamp for this. Current range of clamp should be based on external loads, generally of the same range or a little higher than external load current. When batteries are connected with other loads (equipments are that are running), you could use current clamp to test the amps discharged from the batteries.

For example, if the other loads discharge 10Amps from the batteries, but your target is to discharge 25Amps. Then you could use PITE3980 function “Assistant Discharge” to handle the rest 15Amps.

Firstly, select **[Assistant DIS]** in **[Other Tes]** like:

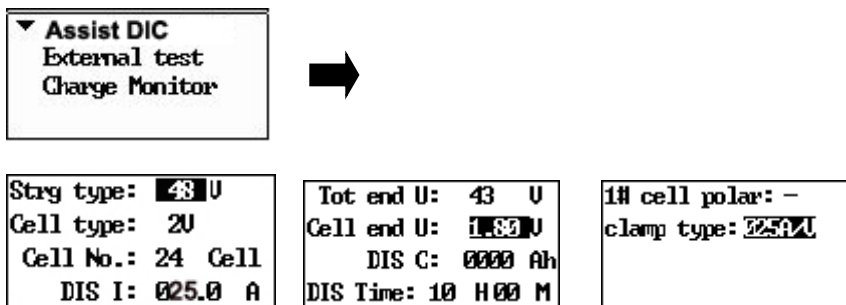

Fig.4.2.1

**[DIS I]** should be set as total current needed. In the above example, it should be set as 25Amps. Other parameter settings are the same as that of **[DIS test]** previously introduced in **4.1.1 Discharge Test**

Set all the parameters in the above three pages. For definition of each parameter, please refer to **4.2.2 External test**. After the setting, select **[Confirm]** to continue the operation:



Fig.4.2.1.1

You will come to the discharge screen after 1 minute of preparation time like below:

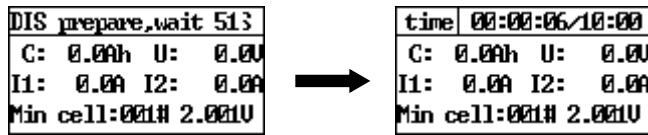

Fig.4.2.1.2

[I1] means total current (including external current and device current).

[I2] means device (PITE3980) current.

Press ↓ to page down to view voltage value of each cell as below:

001#2.003U	005#2.007U
002#2.004U	006#2.008U
003#2.005U	007#2.009U
004#2.006U	008#2.010U

Fig. 4.2.1.3

Press ↑/↓ arrow keys to view voltage values of other cells. After checking all cell voltages, continue with ↓ arrow keys, you will find the 6 cells with lowest voltage as below:

Lowest U cell	
013#2.002U	002#2.004U
001#2.003U	015#2.004U
014#2.003U	003#2.005U

Fig.4.2.1.4

Above screens could be switched to each other during discharging by press ↑/↓ arrow keys.

#### 4.2.2 External test

External discharge test means that the load bank does not discharge batteries. Its main function is to display the values of current clamp and other loads (including battery string). Except battery total voltage and cell voltage (if connected with DACs), all the other values displayed on screen are from outside loads.

To start external discharge, please select [External test] in [Other Tes] like:

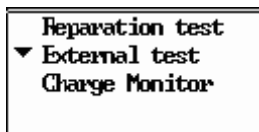

Fig. 4.2.2

Press [ENT] for parameter settings and press ↑/↓ to switch between different pages like:

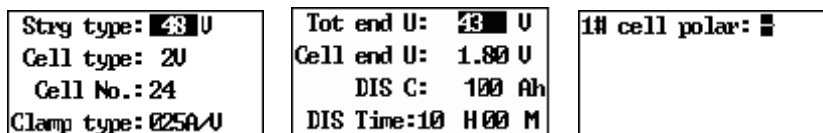

Fig. 4.2.2.1

There are eight items of parameters. including [String type] (optional among 24V, 48V, 110V, 220V and 380V based on different configurations), [Cell type], [Cell number] (set it as 0 when there is no connection of DAC), [Clamp type] (optional among 100A/V, 200 A/V, 400 A/V and 800 A/V based on external loads), [Total cut-off voltage of string]

(normally it is 0.9 time of standard voltage like that of PITE3980 discharging), **[Cell cut-off voltage]** (normally it is 0.9 time of standard voltage), **[Discharge capacity]** (ending value of string discharge capacity), **[Discharge time]** and **[First cell polarity]**.

After setting all the parameters, press **[ENT]** and then select **[Confirm]** below to start discharging:



Fig. 4.2.2.2

Screen of discharge will be like following Fig.:

time	00:00:04/10:00
DIS C:	0.00h
U:	0.00 I: 0.00
min cell:	013# 2.002V

Fig. 4.2.2.3

**[DIS C]** means string capacity already discharged. **[U]** indicates total voltage of cell string. **[I]** indicates the discharged current of external device tested by current clamp. **[min cell]** indicates the cell with lowest voltage during discharging. Like Fig. 4.2.2.3, No.13 has lowest voltage during discharging, the voltage is 2.002V.

Press  $\downarrow$  to page down to view voltage value of each cell as below:

001#2.003V	005#2.007V
002#2.004V	006#2.008V
003#2.005V	007#2.009V
004#2.006V	008#2.010V

Fig. 4.2.2.4

Press  $\uparrow/\downarrow$  arrow keys to view voltage values of other cells. After checking all cell voltages, continue with  $\downarrow$  arrow keys, you will find the 6 cells with lowest voltage as below:

Lowest U cell	
013#2.002V	002#2.004V
001#2.003V	015#2.004V
014#2.003V	003#2.005V

Fig.4.2.2.5

The above screens could be switched to each other during discharging by press arrow keys  $\uparrow/\downarrow$ .

### 4.2.3 Charge Monitor

This is a supplemental function for monitoring data when using external charger for battery string. All the connection of cables for PITE3980 remains unchanged.

To start charge monitoring, select **[Charge Monitor]** in **[Other Tes]** as below:

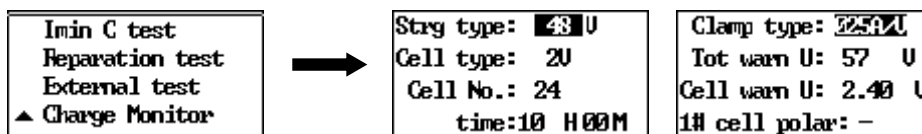

Fig.4.2.3

Press ↓ to page down and set all the parameters. **[Tot warn U]** means upper limit of total voltage. And **[Cell warn U]** means upper limit of cell voltage. After the setting, press **ENT** and select **Confirm** like the following Fig.:



Fig.4.2.3.1

After confirming, you will enter preparation screen like below:

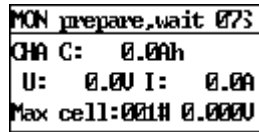

Fig.4.2.3.2

When preparation time ends, it will enter monitoring screen like:

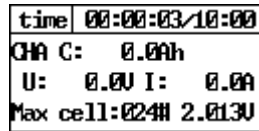

Fig.4.2.3.3

Press ↓ arrow key to view voltages of each cell as below:

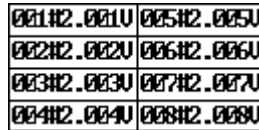

Fig.4.2.3.4

Then continue to page down to view the cells with highest voltages:

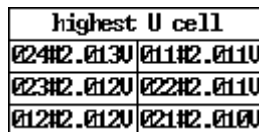

Fig.4.2.3.5

You could also use LB DataView Software to monitor the process of charging. For detailed instruction, please refer to **6.3.1 Real-time Monitor**.

## 4.3 Data Management

Previous testing data could be viewed, transferred to USB drive or deleted in data management section. To do these, please turn to the main menu and select **[Data]**:

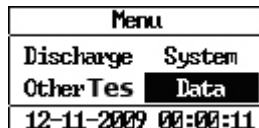

Fig.4.3

### 4.3.1 Read Data Results

After entering [Data], select [View Data], relevant data ([DIS data], [External data] or [Assist data]) and testing date one by one as below:

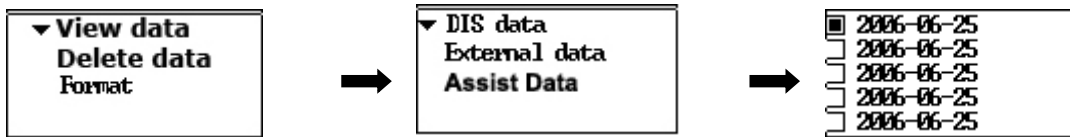

Fig.4.3.1

After selecting the date, press **ENT** and select [View] to see previous testing data:



Fig.4.3.2

Press  $\uparrow/\downarrow$  to page up and down for different parameters as below:

Param setting
Strg type:00
Cell type:00
Cell No.:55

Fig.4.3.3

cell order(ascending)
001#0.000 004#0.000
002#0.000 005#0.000
003#0.000 006#0.000

Fig.4.3.4

### 4.3.2 Load to USB drive

In above Fig.4.3.2, press  $\downarrow$  arrow key to select [WritetoUSB] as below:



Fig.4.3.5

Make sure that you have already inserted the USB drive in the main unit.

### 4.3.3 Delete Data Results

In above Fig.4.3.2, press  $\downarrow$  arrow key to select [Delete] as below



Fig.4.3.3.1

Select the relevant date of testing data as below to delete:

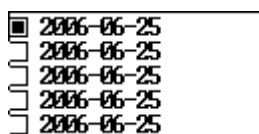

Fig.4.3.2

---

### 4.3.4 Data Format

Select **[Format]** under the menu **[Data]** as below Fig.:



Fig.4.3.4.1

By formatting, all the data saved in the load bank memory will be deleted and could not recover. Please input the password to continue. Default password for data format is 1234.



Fig.4.3.4.2

## 4.4 System Management

For setting of system time, parameter management and functions, please select **[System]** in main menu like Fig.4.4:

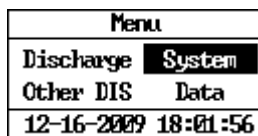

Fig.4.4

### 4.4.1 Time Setting

Select **[Syst time]** under the menu **[System]** and press **[ENT]** like below:

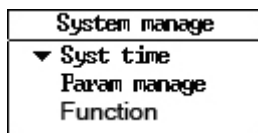

Fig.4.4.1

Use ↑/↓ for different number orientation and use ←/→ to change the numbers.

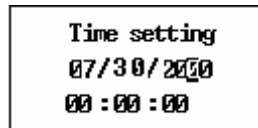

Fig.4.4.2

After the setting, press **[ENT]** to save the setting.

### 4.4.2 Parameter Management

#### 4.4.2.1 Zero Calibration

To ensure measurement accuracy, zero calibration is used when the load bank could not collect discharge voltage and current in normal operation. Steps of calibration are as below:

Please first remove all the wire connection with batteries.

And select **[Zero calib]** under the menu **[Param manage]** to go to the next step:

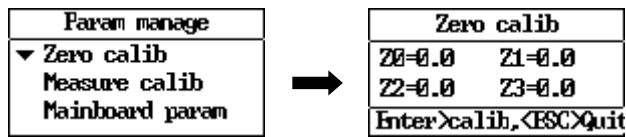

Fig.4.4.2.1

Press **[ENT]** to start calibration as below. When calibration is done, screen will automatically exit.

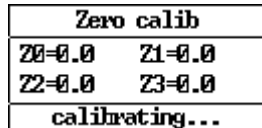

Fig.4.4.2.1.1

After zero calibration, each value will be as below:

Z0: between 5-25 (it could be 0 in old version of hardware)

Z1: 0.0

Z2: between 400 and 600

Z3: between 400 and 600

#### 4.4.2.2 Measurement Calibration

This function is for calibrating the voltage and current values (password is 9577).

**NOTE:** For accurate calibration, please get qualified personnel carry out this function.

To get starting in screen, please select **[Measure calib]** under **[Param manage]** menu and go to the next step as flowchart below:

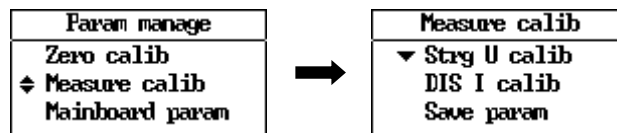

Fig.4.4.2.2

##### 4.4.2.2.1 String Voltage Calibration

For string voltage calibration, you need a high-accurate multi-meter. And voltage testing leads are connected with battery string.

Select **[Strg U calib]** under **[Measure calib]** to go to the next step:

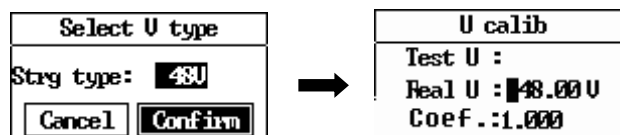

Fig.4.4.2.2.1

Press **←/→** arrow keys to select the string type (based on different PITE3980 models, it is optional among 24V, 48V, 110V, 220V and 380V) .



String type should be identical to the nominal voltage of the Load bank. For example, if your model is 48V/110V 300A, **[Strg type]** here should be firstly selected as 48V. Meanwhile, voltage testing leads should be connected with two poles of 48V cell string. Please mind the correct polarity. Then Press ←/→ arrow keys to input the string voltage value **[Real U]** as per reading of multi-meter. After that, go back to the screen of select V type, select the string type as 110V, this time voltage testing leads should be connected with two poles of 110V cell string, enter the U calibration screen, and input the real value as per reading in the multi-meter.

If your load bank model only has only one nominal voltage (e.g. 48V 300A), you only need to calibrate it once.

After the setting, press **ENT** to calibrate it and go to voltage calibration screen like:

<b>U calib</b>
Test U :
Real U : <b>48.00 U</b>
Coef. : <b>1.110</b>

Fig.4.4.2.2.1.1

#### 4.4.2.2.2 Discharge Current Calibration

It includes inner current calibration and outside current calibration.

Inner current calibration is calibration for the built-in current sensor in PITE3980, while outside current calibration is for external current clamp which is mainly used in other discharge test like charge monitor. For current calibration, you will need an adjustable current clamp as current standard.

##### 1) For built-in current sensor:

Before calibration, connect the load cable between battery and load bank. You'd better use the battery that has higher capacity to prevent the battery from over discharge.

After wire connection, select **[DIS I calib]** under **[Measure calib]** and go to the next step as below:

<b>Select I calib</b>
▼ <b>Inner I calib</b>
<b>Outside I calib</b>

Fig.4.4.2.2.2

Select **[Inner I calib]** for internal current sensor calibration, clamp the adjustable current clamp on either red or black load cable. Press ↑ arrow key slowly on the load bank panel until the current value in current clamp is higher than 70% of load bank maximal discharge current. For example, for a load bank of 48V 300A, the current value in the standard current clamp should be higher than 210A.

Then use ←/→ arrow key to input the current value in **[Real I]** as per the standard current clamp like below, and press **ENT** to confirm. **[Test I]** in the screen below means the testing value by built-in current clamp.

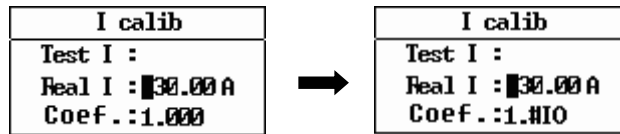

Fig.4.4.2.2.1

**2) For external current sensor:**

Select **[Outside I calib]** for external current calibration. This is for calibrating Optional LB current clamp. To do this, LB's current clamp should be connected with outside DC current like another discharging unit. Then clamp the standard current clamp on LB's clamp cable. Then input current value as per the standard current clamp in **[Real I]** and press **[ENT]** to calibrate it:

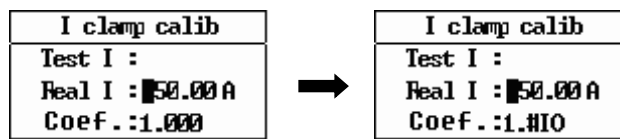

Fig.4.4.2.2.2

**4.4.2.2.3 Save Parameter**

**IMPORTANT:** After all the above calibration procedures are done, please remember to select **[Save param]** to save the operation, password is **9577**:

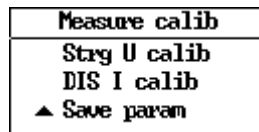

Fig.4.4.2.2.3

**4.4.2.3 String Serial Number Setting**

This is for manually coding certain string number before testing. In analyzing software, these numbers will be needed to distinguish one string from other. Select **[String S/N]** under **[Param manage]** and input your self-defined number as below:

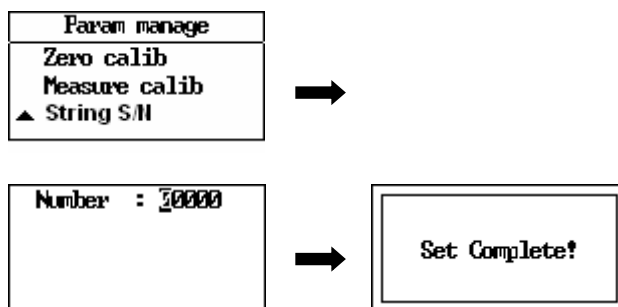

Fig.4.4.2.3

**4.4.3 Function Setting**

These are customized settings for Alarm warning, Battery strings in Parallel, Cell type and String Group.

Select **[Function]** under the menu **[System manage]**, then you see screen like below:

Alarm	No
Parallel	None
Cell type	12U
Str Grouped	No

Fig. 4.4.3

**Description of each function:**

**[Alarm]** setting is to set the warning in BEEP after a discharge is done. If it is not selected, there is silence when discharge is finished.

**[Parallel]** is setting for parallel connection of two load bank to get higher discharge current. It is optional for “2” and “none”. Defaulted setting of all load banks is “2”. For detailed operation of this, please refer to **4.1.4 Parallel Load Test**.

**[Cell type]** is selected to fit DAC type. For example, your DAC can test 2V, 6V and 12V, then select it as “2, 6, 12V”. If your DAC can only test 12V, select it as “12V” and so forth.

**[String grouped]** is used when one load bank hooks up with more than one battery strings (e.g. two) that are in parallel connection. And all these strings come with DACs. These DACs are grouped to fit different strings in the way of String 1 (DAC 1, 2...), String 2 (DAC1, 2...) and so forth. For detailed discharge instruction, please refer to **4.1.2 Discharge for Strings in Parallel Connection**.

## 4.5 Firmware Update

Firmware update for PITE3980 main body is very simple with the following procedure: Copy the two files named like “PROGRAMA.HEX” and “SCRIPT00.TXT” to the root directory of LB USB drive→ Connect the USB drive with PITE3980 main body→ Restart the main body→ You will see update process in percentage→ Firmware update finished.

## 5. SERVICE AND MAINTENANCE

### 5.1 Cleaning

Clean PITE3980 main unit and its accessories with damp cloth and a mild soap. Do not use abrasives, solvents, or alcohol, as they can deform or discolor the load bank and the accessories.

 **WARNING:** For your own safety, make sure that the main unit and accessories are not working and disconnected from the power supply before cleaning.

### 5.2 Storage

After using PITE3980, put the main unit and all its accessories into the carrying case, store the case in ventilating place under proper temperature and humidity. Never expose the load bank and its accessories to water, high humidity, or dampness.

---

## 5.3 Trouble-shooting

If the load bank appears abnormal operation, try the following solutions:

- **No signals on the screen after the load bank is on**  
The power supply may not be connected properly. If so, correct it.
- **Discharge function stops immediately after its startup**  
Maybe the parameter settings are incorrect. If so, reset them.  
Maybe the testing leads are not correctly connected. If so, connect it well.
- **The load bank has no communication with PC**  
Maybe cable for data communication terminal is not properly connected. If so, check it and connect it well.
- **The buttons of the load bank do not work**  
Check to see if the buttons are stuck in the button holes. If they are stuck, press to make them pop-up.
- **The USB drive can not be detected after it is inserted to the PC**  
The USB drive may not be well inserted. If so, reinsert it correctly.  
The USB drive may not be in FAT format. If so, format the USB drive.

For other operation problems, please contact your supplier.