Ground Fault Locator

PITE 3836

User Manual

P-140313-1.5



2/F, Bldg E, Chiwan Industrial Park, Shaodi Rd.,

Chiwan, Shekou Area, Shenzhen, China

sales@pitetech.com

www.pitetech.com

Catalog

| | |
|--|----|
| 1. ABOUT PITE3836 | 4 |
| 1.1 PITE3836 Brief Information?..... | 4 |
| 1.2 PITE3836 Main Functions..... | 4 |
| 1.2.1 Ground Fault Location..... | 4 |
| 1.2.2 Frequency Spectrum Analysis | 4 |
| 1.2.3 Oscilloscope | 4 |
| 1.3 Features..... | 4 |
| 1.4 Typical Application..... | 5 |
| 1.5 Technical Specification..... | 5 |
| 1.6 Composition of PITE3836..... | 5 |
| 1.6.1 Packing List..... | 5 |
| 1.6.2 PITE3836 Main Body | 6 |
| 1.6.3 Signal Receiver | 7 |
| 1.7 Basic Concepts..... | 8 |
| 1.7.1 About Faulty Grounding | 8 |
| 1.7.2 Wire Mix-connection | 9 |
| 1.7.3 Short circuit. | 10 |
| 1.7.4 Current leakage | 10 |
| 1.7.5 Tracing of Current Signal | 10 |
| 2. MAIN OPERATION OF PITE3836..... | 10 |
| 2.1 General Steps for Fault Location..... | 10 |
| 2.2 Operation Preparation..... | 11 |
| 2.3 Wire connection with DC System..... | 11 |
| 2.4 Set Generator Output Signal..... | 12 |
| 2.4.1 Measurement of Circuit..... | 12 |
| 2.4.2 Output Signal Adjustment..... | 13 |
| 2.4.3 Output Signal to Circuit for Fault Location..... | 14 |
| 2.4.4 Return Circuit for Fault Location | 15 |
| 2.5 Signal Tracing with Signal Receiver..... | 15 |
| 2.5.1 Frequency Synchronization | 15 |
| 2.5.2 Set Signal Reference | 16 |
| 2.5.3 How to Locate Ground Fault? | 19 |
| 2.6 Some Tips for Ground Fault Location..... | 20 |
| 2.6.1 Multiple Setting of Signal Reference..... | 20 |
| 2.6.2 Gross searching | 22 |
| 2.6.3 Use more than one signal receiver | 22 |
| 2.7 Signal Changes in Earth Fault Circuit..... | 22 |
| 2.8 Location for Other Ways of Fault..... | 23 |
| 2.8.1 Wire Mix-connection | 23 |
| 2.8.2 Short-circuit Fault Location..... | 24 |
| 2.9 About Distributed Capacitance..... | 24 |
| 3. OTHER SETTINGS OF GENERATOR AND RECEIVER | 25 |

- 3.1 Signal Generator Setting..... 25
 - 3.1.1 Set Date & Time..... 25
 - 3.1.2 Parameter Setting 25
 - 3.1.3 Firmware Version..... 26
- 3.2 Signal Receiver Functions and Settings..... 26
 - 3.2.1 Frequency Spectrum Analysis 26
 - 3.2.2 Oscilloscope 28
 - 3.2.3 System Setting 28
- 4. MAINTENANCE 30
 - 4.1 FAQ..... 30
 - 4.2 Cleaning & Storage..... 31
 - 4.2.1 Cleaning 31
 - 4.2.2 Storage 31
- 5. CONTACT PITE 32

▲ Safety Information

For your protection, please read this safety information completely before operating the locator. Carefully observe all warnings, precautions and instructions.

WARNING: Service information described in this manual is to be done by qualified personnel only. To avoid electrical shock or equipment damage, do not service the instrument unless you are qualified and with PITE's instruction.

| | |
|---|---|
|  DANGER | Safety testing has been done on this instrument thoroughly before shipment. However, mishandling during use could result in injury or other bad consequences, as well as damage to the instrument. Make sure that you understand the instructions and precautions in the manual before use. We disclaim any responsibility for accidents or injuries not resulted directly from instrument defects. |
|---|---|

Safety Symbols

Description of symbols used in this manual.

| | |
|----------------|---|
| WARNING | Indicates correct operation to prevent a significant hazard that could result in serious injury or other bad consequences to users or instrument. |
| NOTE | Indicates advisory items related to performance or correct operation of the instrument. |

▲ Operating Precautions

To avoid electrical shock or fire, read these precautions first before using the locator:

- ◆ Except as explained in this manual, do not attempt to service this equipment yourself.
- ◆ Do not operate the equipment around explosive gas or vapor.
- ◆ Only use PITE's testing leads and other relative accessories with the locator.
- ◆ Before use, inspect the locator, testing leads and other accessories for mechanical damage and replace if necessary. Pay special attention to the insulation surrounding the connectors.
- ◆ Remove all clamps, testing leads and accessories that are not in use.
- ◆ Do not apply the instrument in other purposes that are not described in this user manual
- ◆ Ensure the equipment is provided with adequate ventilation.
- ◆ This manual describes the general operation of the testing system. If your system has features or accessories not addressed in this manual, please contact your supplier.
- ◆ Only qualified technicians are allowed to use the equipment. For fast ground fault location, it will be very important and necessary to familiarize the tested environment, especially the wiring structure of the target site.

1. ABOUT PITE3836

1.1 PITE3836 Brief Information?

PITE3836 is PITE's new generation of ground fault locator applied with advanced technique for earth fault detection. This patent-protected product is built based on years of field experience in different DC systems. It specially deals with current leakage in DC system of high grounding resistance below 1MΩ. Without switching off the DC system, it pinpoints faulty grounding online where electrical lines have breakage and current lost to the ground. It gives excellent solutions for troubleshooting and preventative maintenance.

Compact and rugged design makes the PITE3836 easy to use in small places and harsh environment.

1.2 PITE3836 Main Functions

1.2.1 Ground Fault Location

With comprehensive ways including signal strength, phase change and precise judgment for leakage current direction, it fast pinpoints ground fault.

Based on different distributing capacitance, it selects the right output frequency for testing, which enables it to be widely used in different DC systems.

- Output voltage of signal generator:
selectable among 24V, 48V, 110V, 220V, 500V and 1000V. This will meet requirement for various electric circuit of different voltage levels without interference to the circuit.
- Output current of signal generator:
5mA and unlimited current (limited power with max output current of 30mA). It is selected as per different systems, preventing from incorrect operation of circuit relay.
- Output frequency of signal generator: Standard 10Hz and with options of 1.0Hz, 50Hz, 60Hz and 325Hz which are selectable based on different DC systems.

1.2.2 Frequency Spectrum Analysis

It effectively analyzes the working signal and surrounding interferences signals of DC system. This will help to select the right output frequency for ground fault location and avoid interference by the surrounding signals.

1.2.3 Oscilloscope

It checks waveform of target signal.

1.3 Features

- Patented technology, pinpoint current leakage fault with grounding resistance lower than 1MΩ
- Innovative dual-clamp for signal receiver, each clamp has two sizes of opening jaw for different conductors
- One pair of clamp working together, effective cancel capacitive interference when system is online
- Precise current direction (positive or reversed) indicating for leaking current help fast locate the faulty grounding
- Adjustable output frequency on signal receiver effectively avoids interference from DC system itself

- Signal receiver can set reference in different points for signal comparison, very fast for fault orientation
- Digital signal processing technology for detecting grounding resistance and capacitive resistance
- With built-in band pass filter to bypass different interference signals in the ambient environment.
- No disconnection of the electrical installation, ground fault location is carried out during operation
- Frequency spectrum analysis can test ambient frequencies, helps select the right frequency for the right DC system
- Signal-generator with adjustable output voltage (24V~1000V) and output frequency (1~325Hz) for different DC systems
- Multi-ways to indicate ground fault: sensitive current direction, phase angle, comparison of signal strength.

1.4 Typical Application

PITE3836 is particularly useful in any industry where supply of power for operating measurement, communication and control equipment is critical. Below are some typical areas where PITE3836 is widely used:

- 1) Railway: signal, communication and locomotive electronic equipments in railway
- 2) Communication: electronic equipments of different voltage range with faulty grounding
- 3) Power utility: DC system with faulty grounding, e.g. switchgear in substation
- 4) Others: DC system in aviation, metallurgy, auto works, household appliances and so on

1.5 Technical Specification

| | |
|-----------------------|--|
| Ground fault location | Output voltage: 24V, 48V, 110V, 220V, 500V and 1000V Output frequency: 10Hz (1Hz, 50Hz, 60Hz & 325Hz as option) Output current limitation: 5mA & no limit (max: 30mA) Fault location sensitivity: $\leq 1M\Omega$ Current detect sensitivity of AC/DC circuit: $\geq 0.5mA$ Current sensor: $\varnothing 8$ (8*12mm) and $\varnothing 20$ (30*65mm) two clamps with dual-range |
| Power supply | Signal generator: 4200mAh/16.8V rechargeable Li-ion battery Input: AC220V/110V, output: DC16.8V/2A Signal receiver: 2400mAh/8.4V rechargeable Li-ion battery Charger input AC220V/110V, output:DC8.4V300mA |
| Power consumption | ≥ 4 hours |
| Memory | 16MB |
| Display | Signal generator: 320x240 pixel LCD screen Signal receiver: 240x320 pixel 3.5" TFT touch screen |
| Working temperature | -10°C~55 °C |
| Dimension | L360*W260*H135mm |
| Weight | 7.0 kg |

1.6 Composition of PITE3836

1.6.1 Packing List

Below is picture of PITE3836 main package:



Fig. 1.6.1

Full packing list:

| Item | Parts | No. | NOTE |
|------|-----------------------------|-----|---|
| 1 | Signal generator | 1 | |
| 2 | Power adaptor | 1 | Input: AC110V/220V Output: 16.8VDC/2A |
| 3 | Signal testing lead | 2 | One red and one black 2.5m long each |
| 4 | Alligator clip | 2 | One red and one black |
| 5 | Puncture clip | 1 | Red |
| 6 | Signal receiver | 1 | |
| 7 | Dual-range current detector | 2 | One pair, dual-range (φ8 and φ20) With 150cm long lead |
| 8 | Power adaptor | 1 | Input: AC110V/220V Output: 8.4VDC/300mA |
| 9 | User manual | 1 | This manual |
| 10 | USB drive | 1 | With backup firmware, software and user manual |
| 11 | Qualification certificate | 1 | |

1.6.2 PITE3836 Main Body

Below is picture of PITE3836 main body and functionality of each part.



Fig 1.6.2.1

After turning on the On/Off switch, press any key on the keypad to continue and you will see the main menu as below for each function. Use the arrow keys to highlight each and press **ENT** to confirm the selection or press **Esc** to go back. Main body function and setting will be introduced in detail in this manual later.

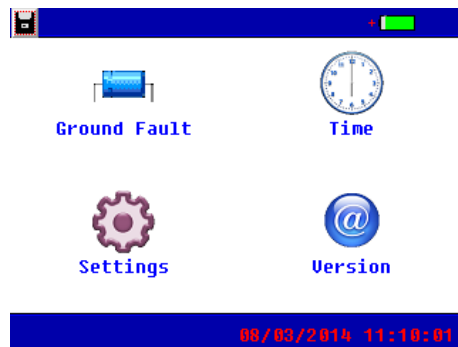

Fig 1.6.2.2

1.6.3 Signal Receiver

All standard units will come with standard signal receiver and one pair of dual-range current detector.

Signal Receiver Main Body:



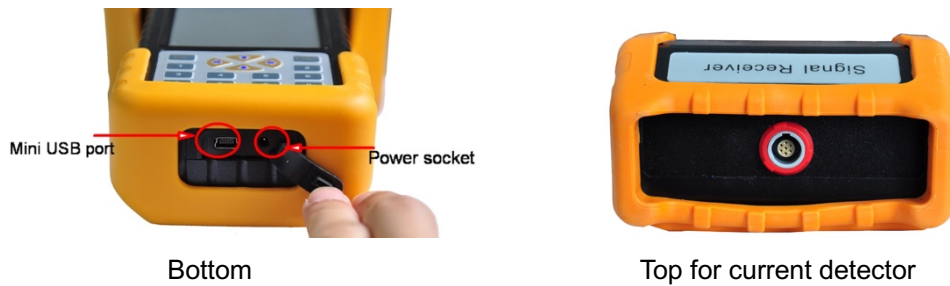

Fig 1.6.3

Standard signal receiver could be operated by touch screen, keypad or quick navigation keys at side. After switching on the unit, you will see the main functions including ground fault location, frequency spectrum analysis, oscilloscope and system setting. We will introduce these functions in detail in the following context.

Current Detector:



Fig 1.6.3.1



Fig 1.6.3.2 Current detectors

Signal receiver main body will be connected with one pair of dual-range current detector like Fig 1.6.3.1. PITE’s innovative designing of dual-range current detector (CT) has 2 different sizes of opening jaw (8*12mm and 30*65mm). Depending on different size of wire or conductors, you could selectively clamp with either size of jaw which have the same effect.

Also, with one pair of current detectors working at the same time in the circuit, PITE3836 will have strong capability for anti-interference. Therefore, it could check ground fault effectively even when system is online without switching off the DC system.

Each current detector has labels of arrow mark at both sides. The arrow marks are used for current direction indication during ground fault location. For detailed operation instruction of dual-range current detector, please refer to Section “2.5 Signal Tracing with Signal Receiver”.

1.7 Basic Concepts

1.7.1 About Faulty Grounding

AC or DC power systems are generally insulated to the ground in railway electric works, power substation, telecom base station and the alike. There are also clear and strict rules for insulating resistance in different voltage levels of AC or DC power systems.

And it is generally considered as the phenomenon of faulty “Grounding” when grounding resistance of one

point (or multi-points) becomes lower than tolerance value. Take following chart for example, Point A is the grounding point, R is the grounding resistance, C1 and C2 indicate distributed capacitances before and after the malfunction point.

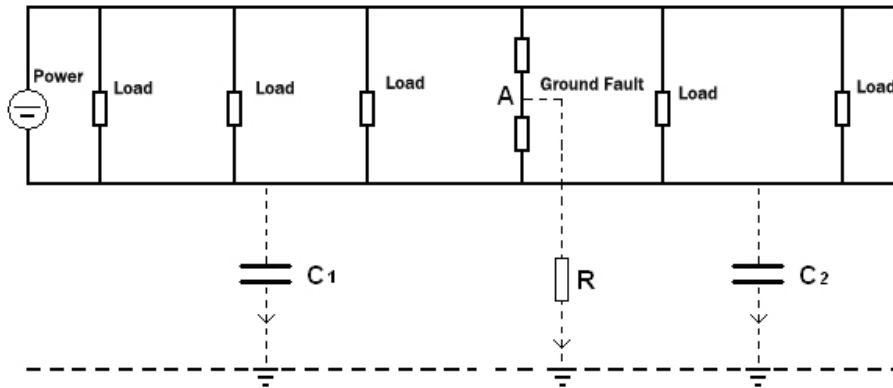

Fig 1.7.1

When one point of circuit has unwanted grounding like this, protection equipments, signaling equipments and automation equipments may have incorrect operation or may stop running, or fuse will burn out and thus cut off power supply for protection equipments, automation equipments, controlling circuit and communication signaling system.

If one point problem is unsolved for long time until more points have the same problem, it may damage electronic circuit or equipments. Therefore, unwanted grounding of electronic circuit is very big hidden danger. Therefore, a fast detection of ground fault will be very necessary before “small” problem becomes big accident.

1.7.2 Wire Mix-connection

Sometimes two or more groups of power systems are working simultaneously, and normally they are insulated from each other. When insulating resistance between these individual powers become lower than required value in one point or more points, we call it as “wire mix-connection”. Below is one example. Point A and B are malfunction points. R indicates the mix-connection resistance. C1 and C2 indicate the distributed capacitances.

Wire mix-connection is common problem in signaling system in railway. It also has big hidden hazard like faulty grounding.

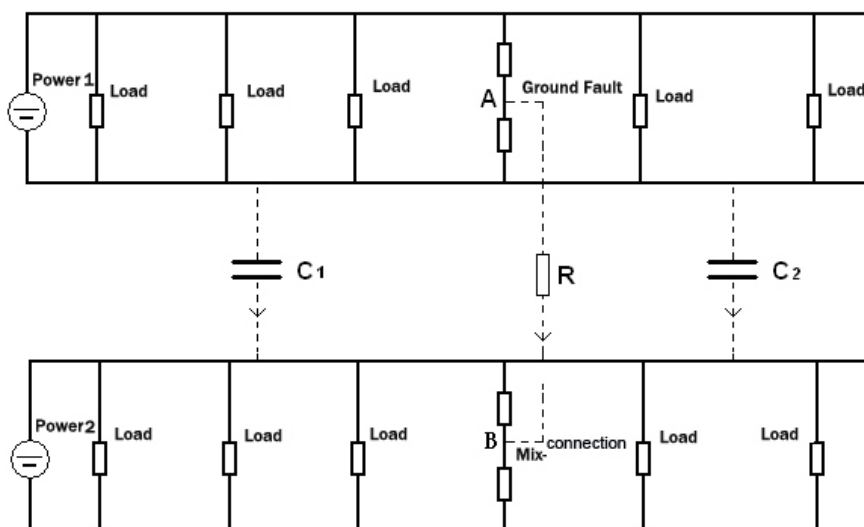

Fig 1.7.2

1.7.3 Short circuit

One power system generally comes with several loads working together at the same time. Normally when all loads are disconnected, power output current becomes 0 Amps. However, when insulating values of one point or more are lower than requirement but there is still current flow, we call it as “short circuit”. In this case, positive busbar is short-circuited to negative busbar.

Short circuit will increase power consumption and may even burn up power supply and cause other bad accidents like faulty grounding.

1.7.4 Current leakage

Circuits, which are normally insulated to the ground, have current flow to the ground due to bad insulation or circuit distributing capacitance.

1.7.5 Tracing of Current Signal

When we are using the PITE3836 to locate the faulty grounding, signal generator (main unit) will send a “current signal” in certain frequency to the circuit. This current signal will flow in the circuit. With a signal receiver (connected with a current detector), we will trace the current signal in different points of the circuit. In comprehensive ways of signal judgment like current direction, signal strength and phase angle, we will fast locate the ground fault.

For detailed ways to pinpoint the faulty grounding, we will introduce in Chapter 2 below.

2. MAIN OPERATION OF PITE3836

2.1 General Steps for Fault Location

For ground fault location, we will generally follow these steps:

- 1) Measurement preparation
Familiarize with the wiring structure of DC system and judge which line has faulty grounding.
It is very important to know the wiring structure on how the wires are connected in the DC system.
This will help you fast trace the ground fault.
- 2) Connect the signal generator with DC system.
When positive busbar has ground fault, connect red testing lead with positive busbar and black lead with ground. When negative busbar has fault, connect black lead with negative and red lead with ground.
- 3) Set output signal in signal generator and set signal mode as “Continue”.
Signal generator will test output voltage, current and grounding resistance.
- 4) Do frequency synchronization in receiver
- 5) Proceed with “Reference setting” in signal receiver
- 6) Follow the theory of ground fault location to pinpoint the faulty grounding one by one.
- 7) Make a record for the signal strength for each branch for signal comparison afterwards. If necessary, set the reference several times for better comparison.
- 8) Solve the problem of faulty grounding as per requirement.

Here, we will explain deeper for each steps.

2.2 Operation Preparation

You are suggested to prepare well as below before going to the field for earth fault tracing::

- 1) Make sure that both PITE3836 signal generator and receivers are fully powered. Signal generator can work with power adaptor connecting with AC power supply.
- 2) Familiarize with onsite wiring for target DC system. It will be very important and helpful to have the detailed wiring instruction indicating how each equipment is connected in the whole DC system.
- 3) For security purpose, please wear helmet, insulation-protected gloves and other protecting facilities during operation.
- 4) Judge which busbar has faulty grounding:

A. DC circuit:

Use a multi-meter, switch to DC voltage measurement mode, and respectively measure the voltage between busbar (negative and positive) and ground. Normally both absolute values should be equal (around half of nominal voltage). If one of the voltage values is lower, this busbar should have faulty grounding.

B. AC circuit:

Switch the multi-meter to AC voltage testing mode and respectively test the voltage value between each power line (phase line and null line) and ground. Normally both absolute values should be the same. If one of the voltage values is lower, that line should have earth fault.

- 5) Connect testing leads with signal generator and current detectors with signal receiver.

2.3 Wire connection with DC System



Fig 2.3.1

First connect the testing leads with signal generator, red lead with red socket and black lead with black socket (Fig 2.3.1). Make sure that they are not mixed up. Then connect other ends of the leads with alligator clips. After correct judgment on which busbar has ground fault, connect the testing leads with the DC system as below:

- 1) If positive busbar has ground fault, connect red lead with positive busbar and black lead with ground.

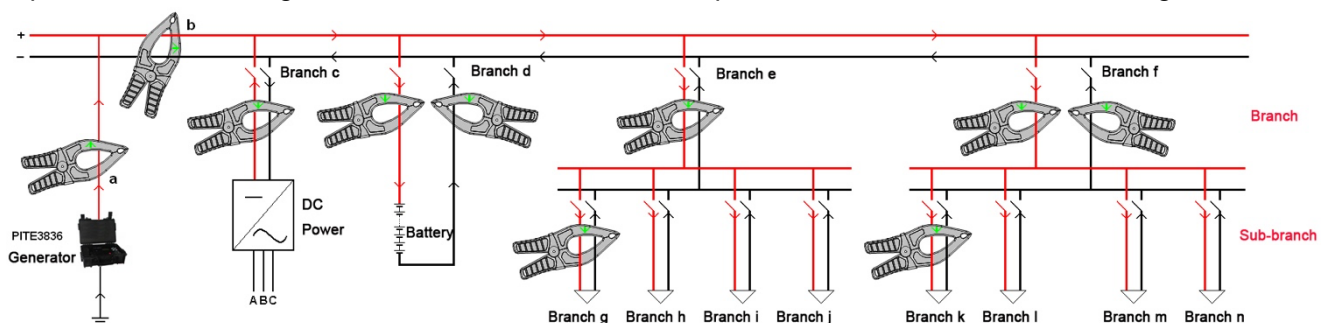

Fig 2.3.2 Fault on positive busbar

2) If negative busbar has fault, connect black lead with negative and red lead with ground.

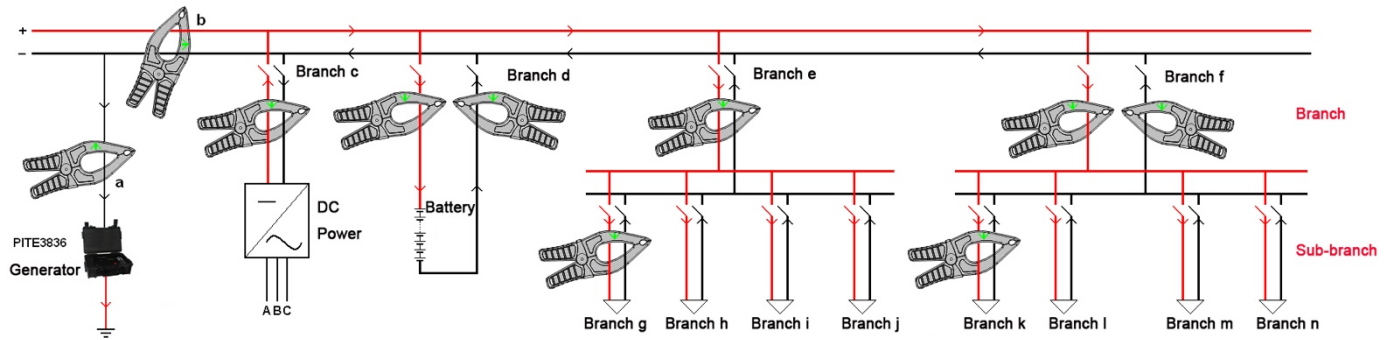

Fig 2.3.3 Fault on negative busbar

Drawings of current clamp in these two circuit diagrams are for your reference only. We will explain for their operation in detail in coming context.

Note: If there is no conductor in busbar to connect the testing clip for signal injection, you are suggested to use the red puncture clip to pierce the insulated cable.

2.4 Set Generator Output Signal

2.4.1 Measurement of Circuit

After the signal generator is well connected with the DC circuit, please turn on the unit, you will see the main screen as Fig 2.4.1.1. Use arrow key to highlight “Ground Fault” and press **ENT** to select it. You will go to the next screen for output signal setting like Fig 2.4.1.2.

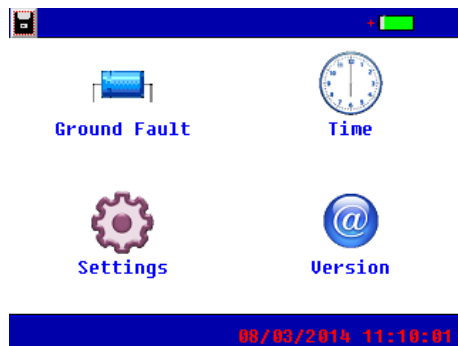

Fig 2.4.1.1

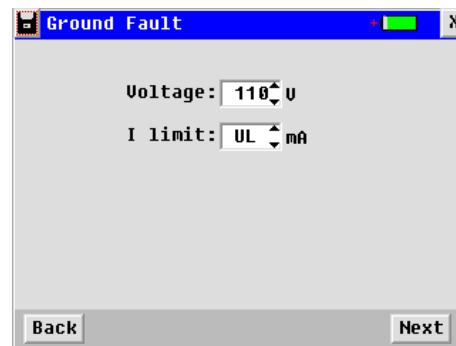

Fig 2.4.1.2

You will need to set the output voltage and output current. Their setting will be:

➔ **Output Voltage:**

Optional among 24V, 48V, 110V, 220V, 500V and 1000V. Generally the selected output voltage should be same or one level higher than system voltage. For example, if it is DC110V substation, then please select 110V or 220V as output voltage.

➔ **Output Current limit:**

Has options of “5mA” and “UL” (unlimited).

Current limit of 5mA means that the signal generator will output a signal with maximal current of 5mA. Based on different circuit signals, output current will be adjusted automatically up to 5mA.

In the condition of “UL”, it will be based on limited output power (5w) with maximal output current of 30mA.

Warning!

To avoid unwanted operation of relay in the DC system, please select current limit properly. In signaling circuit of railway station, over 5mA output current will cause unwanted operation of relay. In such circumstances, you are suggested to select 5mA. Otherwise, you are always suggested to select “UL” (limited power) to maximize the signal for faster signal tracing.

Select output voltage level and current limitation and click **Next** to continue. The signal generator will have an initial measurement for distributed capacitance(C), output current(I) and grounding resistance(R) (Fig. 2.4.1.3). Display of waveform is in square wave. The waveform indicates output voltage (blue) and current (red) of signal generator. Numbers (e.g. 219 56 200 in Fig 2.4.1.3) above the waveform indicate respectively maximal, average and minimal sampling value of voltage and current.

Note:

For definition of distributed capacitance and its relationship with resistance and frequency, please refer to “2.9 About Distributed Capacitance”.

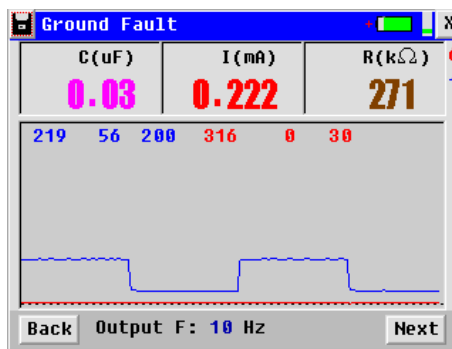

Fig 2.4.1.3

2.4.2 Output Signal Adjustment

The initial measurement gives you a brief idea about the fault signal in the circuit. You may alternatively adjust the output signal in the next screen as below by pressing button **Next**.

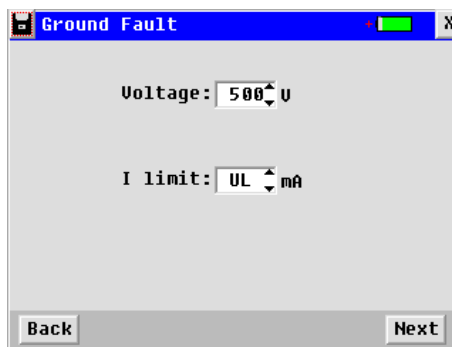

Fig 2.4.2

1) Adjustment for output voltage:

If the current signal is not strong enough (lower than 1mA) in the previous measurement, you are suggested to increase the current signal by increasing output voltage to a higher level.

2) Adjustment for output current limitation:

Change the current limitation as 5mA or UL if necessary.

About output Frequency:

The defaulted output frequency is set as 10Hz, which makes it simpler for users' operation. Based

on PITE’s years field experience, 10Hz output frequency will fit most DC systems for fast location of earth fault. Generally it is no need to change.

If you have particular DC system that needs other output frequency, please first change the setting in Section “3.1.2 Parameter Setting”. And also do frequency synchronization as per steps in Section “3.2.3.1 Frequency synchronization”.

2.4.3 Output Signal to Circuit for Fault Location

After above adjustment, click **Next** to continue. You will see the screen like Fig 2.4.3.1 with output voltage, current, grounding resistance and waveform. Defaulted waveform is displayed as “Continued”. You could use arrow key to change the view as “Discontinue” which will have 1 second interval. Different ways of display is illustrated as diagram in Fig 2.4.3.2 and Fig 2.4.3.3.

NOTE: For ground fault location, please set signal display as “Continue”.

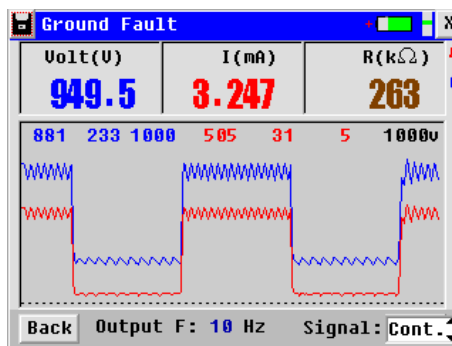

Fig 2.4.3.1

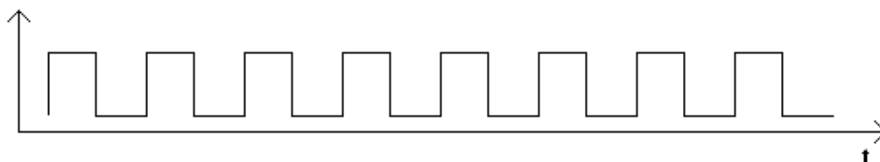

Fig 2.4.3.2 continued waveform

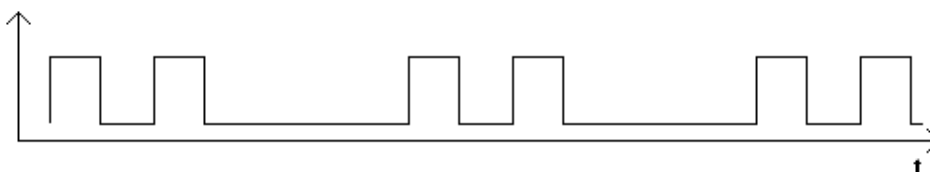

Fig 2.4.3.3 Discontinued waveform

1000V on the right side of screen (Fig 2.4.3.1) indicates the output voltage. Numbers on the right column (e.g.4 and 0 in Fig 2.4.3.1) are for PITE’s R&D purpose, users can neglect it. All these numbers in the screenshots are for reference only; they are different in different circuits.

Signal auto adjustment:

After adjustment for output signal, the output voltage may still be automatically increased or decreased to a proper value in the screen like Fig 2.4.3.1.

This auto adjustment will help users gain better signal for ground fault location. Meanwhile, it will prevent the signal from being too strong to damage the DC system.

2.4.4 Return Circuit for Fault Location

After the above signal injection from signal generator, there will be return circuit like the exemplified diagram below.

Supposed that the fault is on positive busbar on the point called “Fault 1”, the current signal injected from PITE3836 signal generator will go all the way to the point “Fault 1”, outflow to the ground, finally goes back the signal generator via the testing lead and thus form a return circuit.

This return circuit is important for signal tracing using a signal receiver. And this is the working principle for PITE3836 Ground Fault Locator.

For detailed explanation of the theory on signal tracing, please refer to Sections from 2.5 to 2.7.

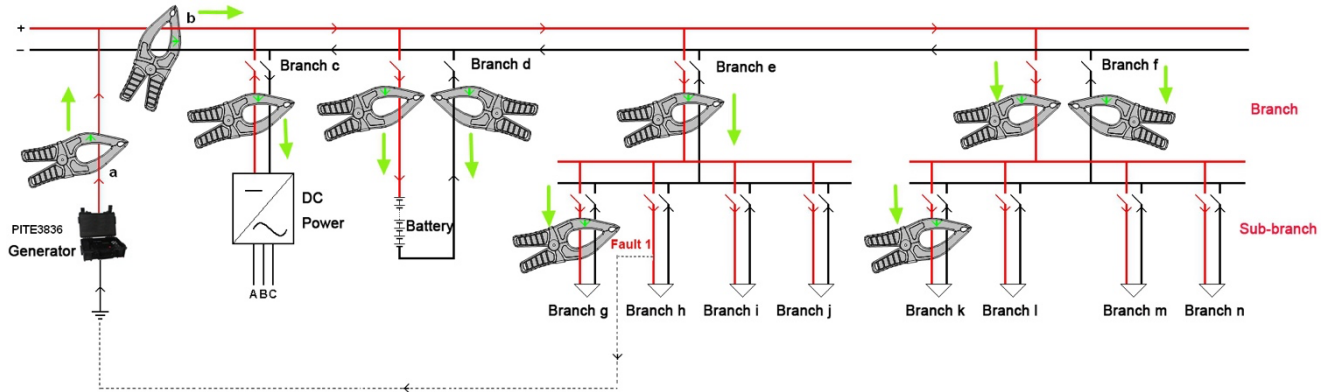

Fig 2.4.4 Example of current flow

2.5 Signal Tracing with Signal Receiver

After the above setting and measurement on signal generator, you could leave the generator alone as long as there is enough power. Otherwise, connect the AC power adapter during operation. Then the signal receiver will take charge of the rest work for signal tracing.

Note:

Use the signal receiver for signal tracing ONLY after the signal generator is in the last screen like below (after signal adjustment and with “continued” signal)

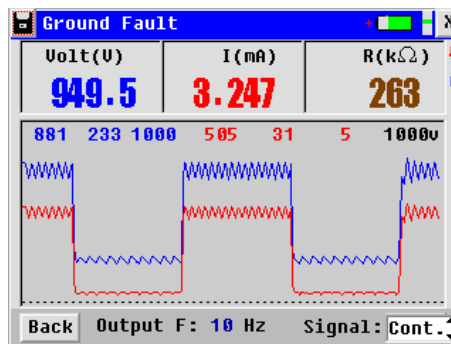

Fig 2.5

2.5.1 Frequency Synchronization

Before we start signal tracing, make sure that frequencies of signal generator and receiver are identical. In factory default setting, both signal generator and receiver have frequency of 10Hz. In this case, you do not need to change frequency or set frequency synchronization. Then please skip and to Section 2.5.2 below.

If your signal generator has a different output frequency, please refer to “3.2.3.1 Frequency

synchronization” for setting instruction.

2.5.2 Set Signal Reference

After signal receiver is connected well with current detector, turn on the receiver and select “Ground Fault”. You will see the screen for frequency setting as below:



Fig 2.5.2.1

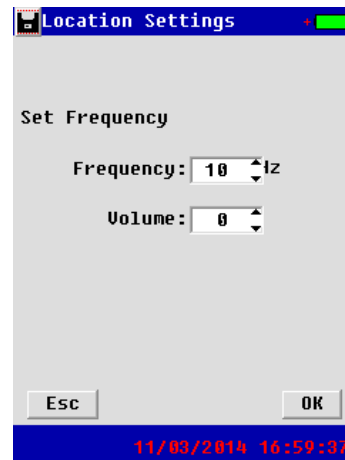

Fig 2.5.2.2

After frequency synchronization, receiving frequency 10Hz is kept unchanged. Volume setting has option from 0 to 9. For example, if setting volume is 4, when detected signal is higher than 40%, signal receiver will BEEP. Screenshot like below (Fig 2.5.2.3) indicates 40% signal strength.

➔ Signal Reference Setting

This is very important step for PITE3836 during ground fault location.

After initial setting for receiving frequency and audio, click **OK** to proceed in the screen like Fig 2.5.2.3. Before reference setting, signal strength in the screen can be any number.

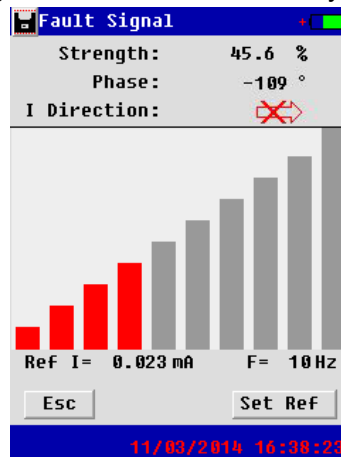

Fig 2.5.2.3

➔ What is reference setting?

When the signal generator injects a current signal into the DC circuit, this current signal can go anywhere and finally outflow to the point of fault. Since there are too many branches and sub-branches in real DC system, the signal will become weaker and weaker, which will make it very difficult to trace.

To make signal tracing easier, we use the term of “Signal Reference”. It will help compare different signals more effectively to sort out the real fault.

At the start of the circuit (output of signal generator), set the reference point as 100% signal strength.

Future signals will be compared against the reference point. For example, at the start of the circuit, referred to Point A in the following diagram, its current value of 20mA is set as 100%. Down the circuit, at Point C, its current value of 10mA will become 50%.

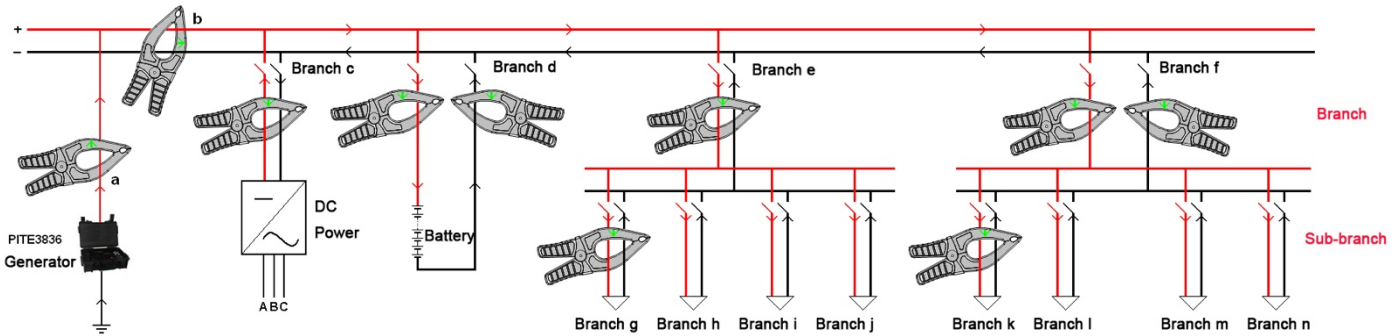

Fig 2.5.2.4

➔ **Reference Point setting for the first time**

IMPORTANT: Please do the reference setting only AFTER signal generator is connected with the DC circuit and injects signal properly (in the last screen like Fig 2.5).

Take Fig 2.5.2.5 for example, after signal injection, the signal at the beginning (close to red socket on signal generator) of red testing lead is strongest. If in Fig 2.5.2.6, beginning of black testing lead will have strongest signal. In the explanation below, we will use the first situation as example (Fig 2.5.2.5).

1) When positive busbar has fault:

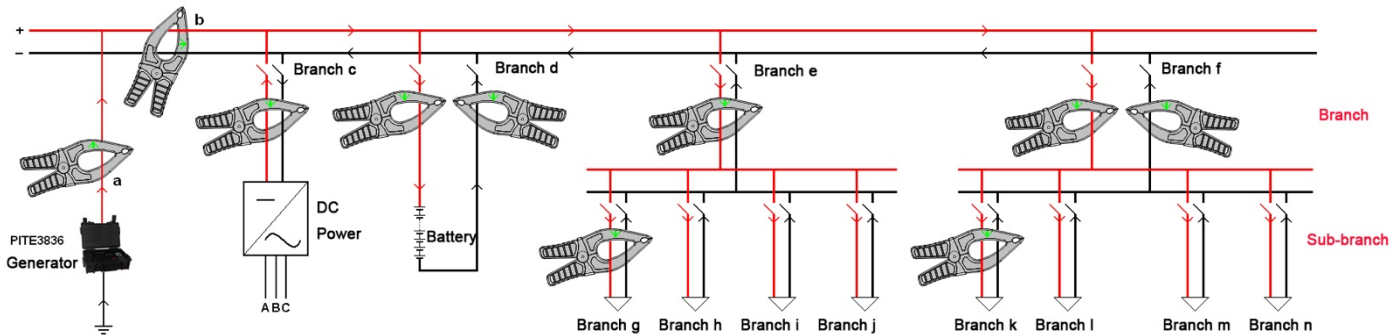

Fig 2.5.2.5

2) When negative busbar has fault:

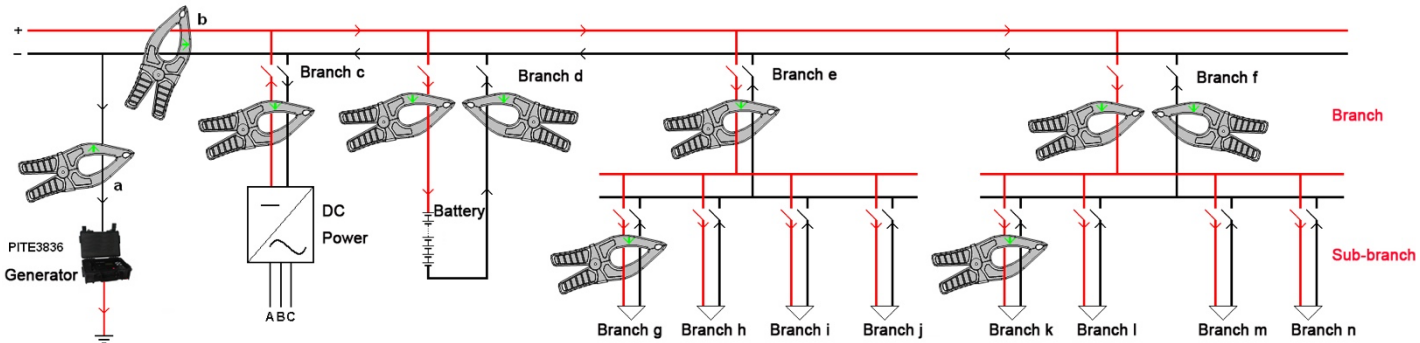

Fig 2.5.2.6

For the first reference setting, please clamp only ONE of the two current detectors around beginning of

red testing lead with the arrow mark (label on the clamp) pointing towards the direction of faulty point as Fig 2.5.2.7. Keep the current detector stable for around 5 seconds and then click the button **Set Ref** in the screen of signal receiver.

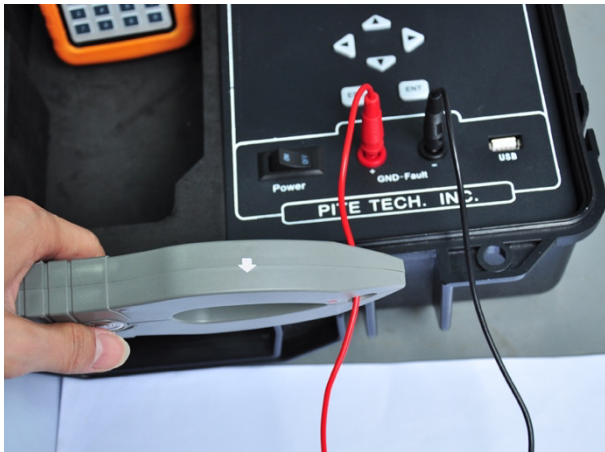

Fig 2.5.2.7 Correct connection

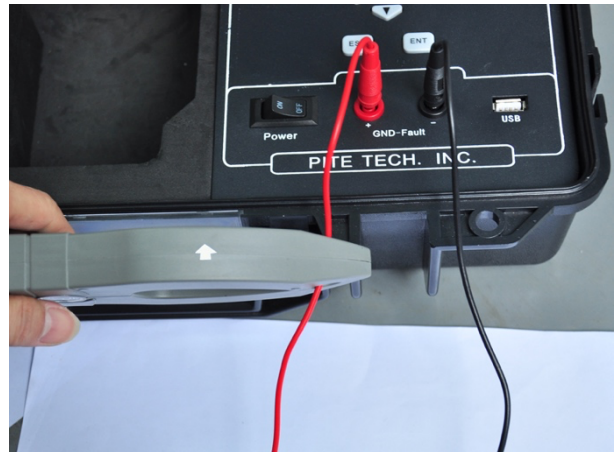

Fig 2.5.2.8 Incorrect connection

After reference setting, signal strength of reference will be set as 100%, phase angle becomes 0° and current direction will be positive (Green like).

Below are the examples before and after reference setting. “Ref I” is the current value at the reference point. Before setting reference, this value is always defaulted as 1.000mA.

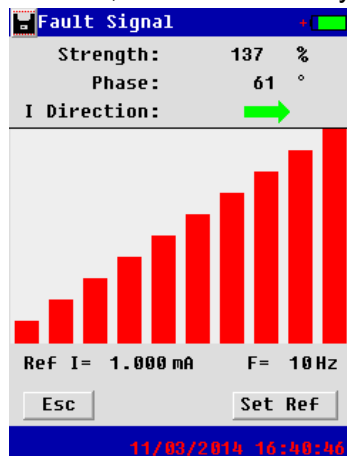

Fig 2.5.2.6 Before setting

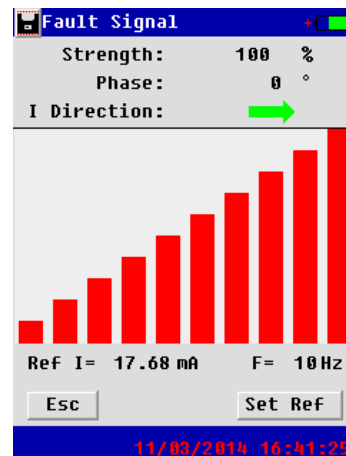

Fig 2.5.2.7 After setting

Red columns in middle of the screen indicate strength of signal in percentage. It will increase one column when signal increases by 10%.

NOTE:

- 1) Only use ONE current clamp for reference setting. Do not use two clamps.
- 2) Before setting, make sure to set signal as “Continue” in signal generator (Fig 2.5).
- 3) Although you could set the reference for many times, please make sure to clamp in the circuit that has current flow (before the point of fault) and with arrow pointing towards earth fault.
- 4) If reference setting is done when there is no current flow at all, signal display in receiver after the reference setting will be a misleading to you.
- 5) When there is fault on negative busbar, wire connection is like Fig 2.5.2.6. And in reference setting, the current clamp should be connected with black testing lead in the same way like Fig 2.5.2.7 (arrow mark towards the faulty point).

2.5.3 How to Locate Ground Fault?

After the reference setting, we will continue with the most important part for signal tracing with the help of dual-range current clamp. Let us refer to the following diagram again:

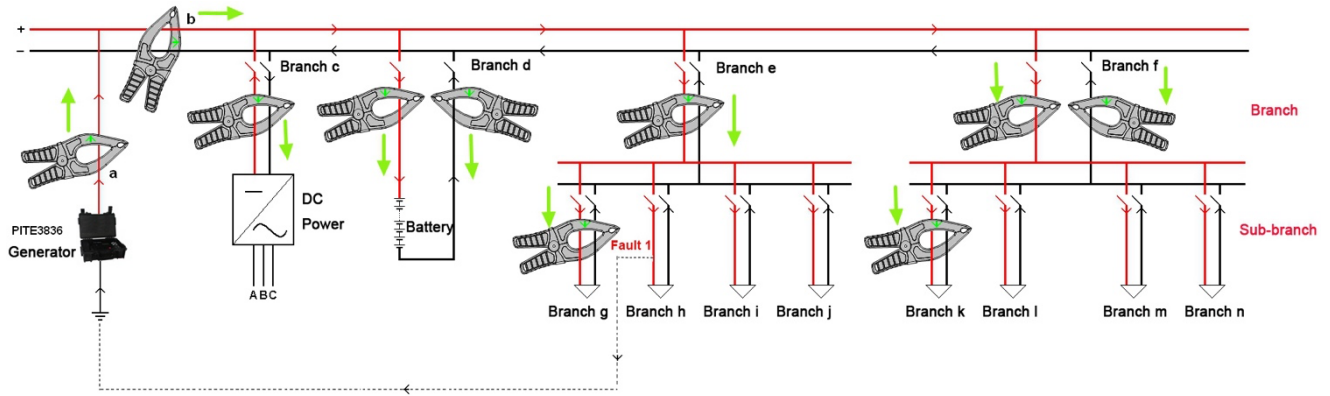

Fig 2.5.3

➔ Solution for Online fault tracing

In most DC systems (like power substation), it could not be shut down. So the fault tracing will be carried out when the system is working online. In this case, there will be high interference that is generated by distributed capacitance from the circuit itself. With PITE’s dual-range current clamp, it can effectively cancel the interference and pinpoint the fault much faster.

➔ Steps for fault location

Take the diagram in Fig 2.5.3 for example (supposed that positive busbar has ground fault).

1) Sectionalize the DC system

After setting for the first reference point in Point a, we will sectionalize the DC system as different “Levels”. The first level will be Branches of b, c, d, e and f. The second level will be Branch g, h, i, j, k, l, m and n. All these branches are connected with loads which has input (red line) and output (black line). And you could consider all cabinets in power substation as bigger loads with many smaller loads inside.

As the earth fault is on positive busbar, the signal tracing will follow all the way based on positive busbar. We will begin the signal search from the first level.

During the process of signal tracing, it is very important to have a detailed record about the wiring structure on how each load is connected in the system. This will help you trace the signal effectively.

2) Use one-clamp or two-clamp tracing

Use one clamp to clamp around input and output of the load when these two lines are very close to each other (like Branch b, c and e in Fig 2.5.3).

Use two clamps to clamp around the input and output line of load when input and output lines are far away from each other (like Branch d and f in Fig 2.5.3).

Note: If one load has more than one input line or output line, connect the clamp around all the input and output lines.

One-clamp and two-clamp operation have the same purpose: to cancel the interference generated by DC system itself. Also, the arrow mark direction (label on the clamp) should always be the same (pointing towards the same load). The green arrow directions in Fig 2.5.3 indicate the right direction



for current clamp in different situations.

Important: Arrow direction of the current clamp in the circuit should strictly follow these rules.

Suggestion: When you connect the current clamp with input and output lines, please keep the clamps steady for around 5 seconds to make signal stable.

3) Signal judgment

Follow the signal indication of signal strength, phase angle and current direction in the signal receiver.

If receiver indicates , the faulty point is in the same direction with arrow in current detector. You should follow the arrow direction. If it indicates , then they are in the opposite direction or current clamps are put in the wrong way.

4) The faulty branch has stronger signal

There is always big difference of signal strength, arrow direction and phase before and after the branch of earth fault. In Fig 2.5.3, there is almost no signal or only weak signal in Branch f. However, Branch e has stronger signal than all the other branches (c, d and f) in Level 1. As there is no fault in DC power (Branch c) or battery string (Branch d), signal indication are very weak or almost no signal there.

In the same way, Branch h has stronger signal than all the other branches (g, i and j) in Level 2.

Therefore, during signal tracing for the earth fault, we should always follow the stronger branch.

5) Use multi-setting of signal reference

For details, please refer to “2.6.1 Multiple Setting of signal reference”.

Above are just general steps for signal tracing using the signal receiver. For further illustration of ground fault location, please refer to Section 2.6 and 2.7 for the location theory and measurement tips.

2.6 Some Tips for Ground Fault Location

2.6.1 Multiple Setting of Signal Reference

Many DC systems contain hundreds of electric branches across 2 to 3 levels or even more, each level might consist of dozens of branches. Due to the existence of distributed capacitance and sometimes AC signal, there will be current leakage in the system. This can result in a very weak current signal in the grounding branch. (Ex. Less than 10% of the reference point.)

1) Determine location of weak signal:

Take Fig 2.6.1.1 for example, the signals from Branch g, h, i, and j are very weak compared with Branch e. It is difficult to judge which lower branch has the fault due to the weak signal. In this scenario, the reference point should be adjusted on the lower branch.

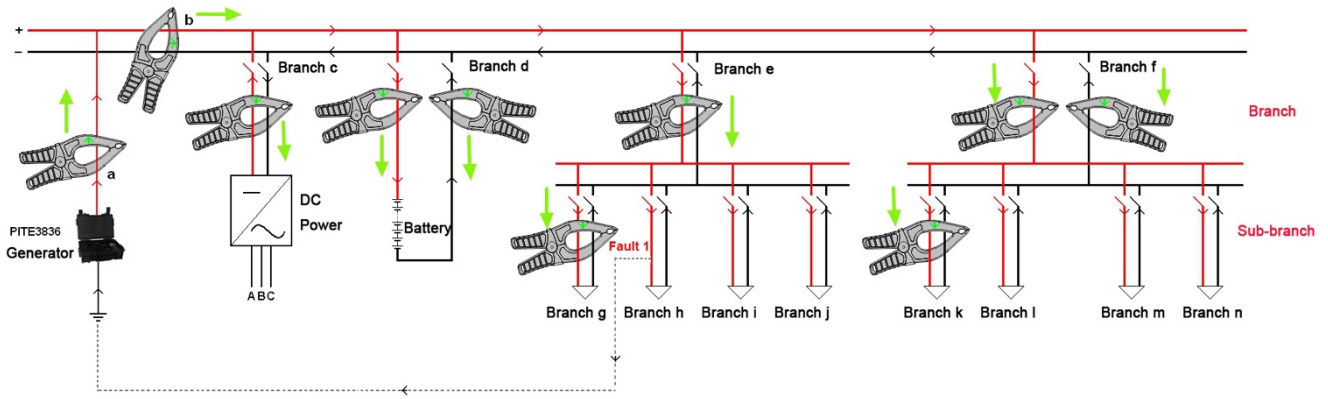
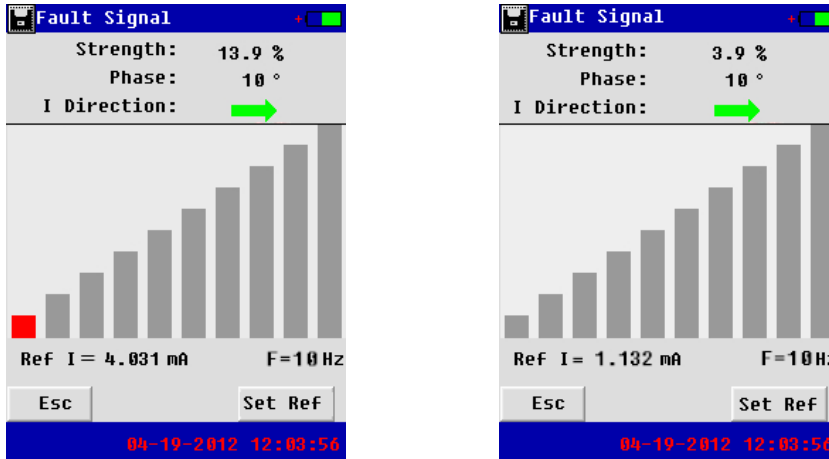

Fig 2.6.1.1

2) Determine new reference point:

A new reference point should be set on the lower branch with the highest signal. In this example, Branch h was measured with the highest signal, as shown in Fig 2.6.1.2 (compared with Branch g).



Branch h

Fig 2.6.1.2

Branch g

3) Set new reference point:

Set the new reference point on the branch with the highest signal. In this example, Branch h was used as the new reference point. After setting the reference point to 100% for Branch h, the signal from Branch g is now greater than 10%.

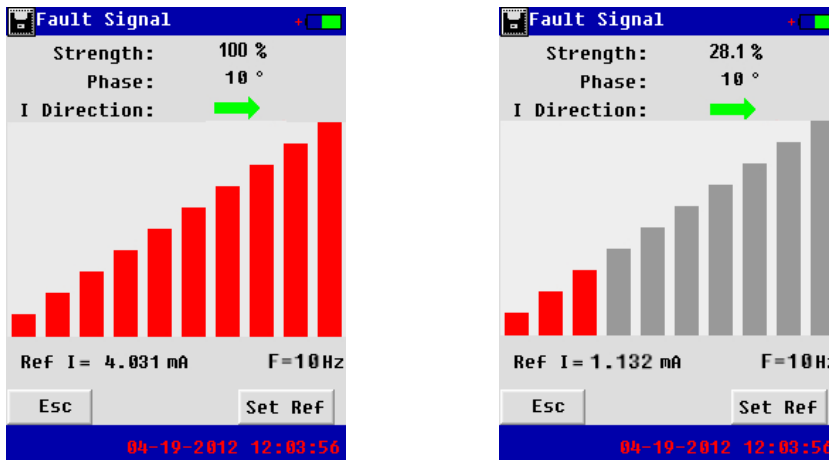

Branch h

Fig 2.6.1.3

Branch g

Note:

- In new reference point setting, please still use only ONE clamp with arrow mark point towards the fault, same as the first reference setting. Clamp it around red line if fault is on positive busbar, otherwise, clamp around black line.
- You are strongly suggested to make the record on where you set the second reference point and with what current strength. You may have to come back and trace the second highest signal (can be another fault) in the same Level.

2.6.2 Gross searching

Physically divide the DC system into several sections. For example, in power substation, there are different cabinets in the same DC system. These cabinets can be chargers, switchgears, control panels and so on which we consider as different bigger loads. Wiring structure could be complicated and most of the time different wires are tied together.

In this case, you do not need to check wire by wire. You could connect the current clamp around input and output terminal of each cabinet (load) to see the current strength, phase angle and direction compared with reference point. Most of the time, input and output of this cabinet (load) are bound together; you could just use one clamp. If they are far away, use two clamps with arrow mark pointing to the load.

This way of gross searching will be time saving and no need to take out all the wires that have been tied together inside the cabinets. But when using this way, make sure that you are familiar with the wiring structure of the DC system, which will help you find out the fault much faster.

2.6.3 Use more than one signal receiver

To save time, you could have more personnel holding more signal receiver checking simultaneously to narrow down the scope of signal searching. All PITE3836 signal receivers (of same frequency) could be used at the same time independently for ground fault location. They can have separate setting for reference point which will not affect each other.

2.7 Signal Changes in Earth Fault Circuit

We have explained in detail on how to pinpoint the ground fault in the previous context. Here is further illustration for signal changes in the circuit.

Supposed that there is ground fault on positive busbar as exemplified in Fig 2.7, red testing lead is connected with positive busbar and black lead with ground. Branch c has ground fault.

Signal generator will inject a voltage signal in the circuit. Due to the existence of distributed capacitance and grounding resistance, there will be leakage current. Current signal and phase changes will be like (b) and (c) in Fig 2.7. There will be sudden changes before and after the point of fault. Phase angle will be lowest at the point with ground fault.

In the diagram, branch c has a grounding resistance R . I_R is the resistive current. C_1 and C_2 are distributed capacitance. I_{c1} and I_{c2} are capacitive current.

If there is more than one point that have ground fault, you are suggested to find out the point of fault that

has strongest signal and step by step to all the other faults.

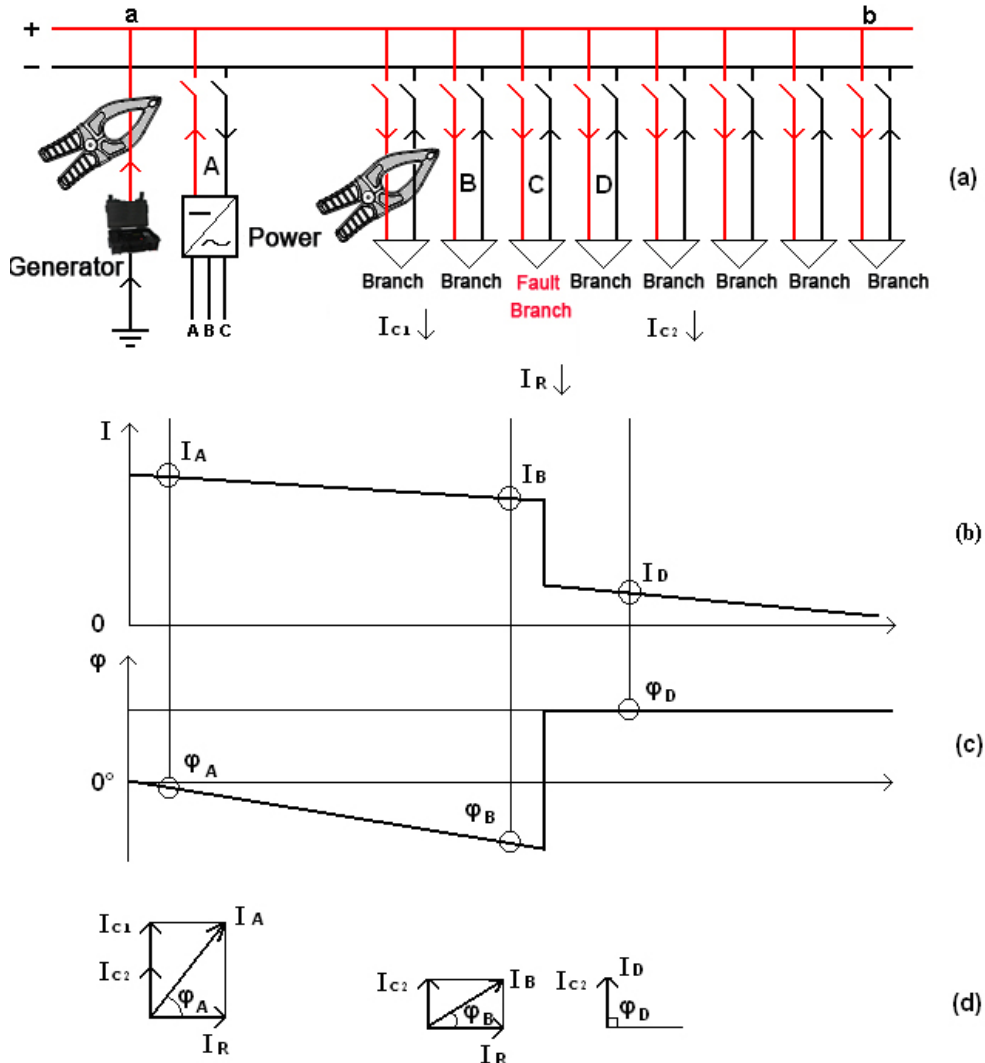

Fig 2.7

2.8 Location for Other Ways of Fault

2.8.1 Wire Mix-connection

Location of mix-connection fault is same like that of ground fault location. The difference is that signal generator injects the current signal in the two lines that are mix-connected (see Fig 2.8.1 for wiring instruction). Then trace the current signal with the signal receiver in the same rules like ground fault location as explained before.

If both of the two lines are accidentally grounded, they are mix-connected through the earth. Then please check the ground fault of each line as DC ground fault location described previously.

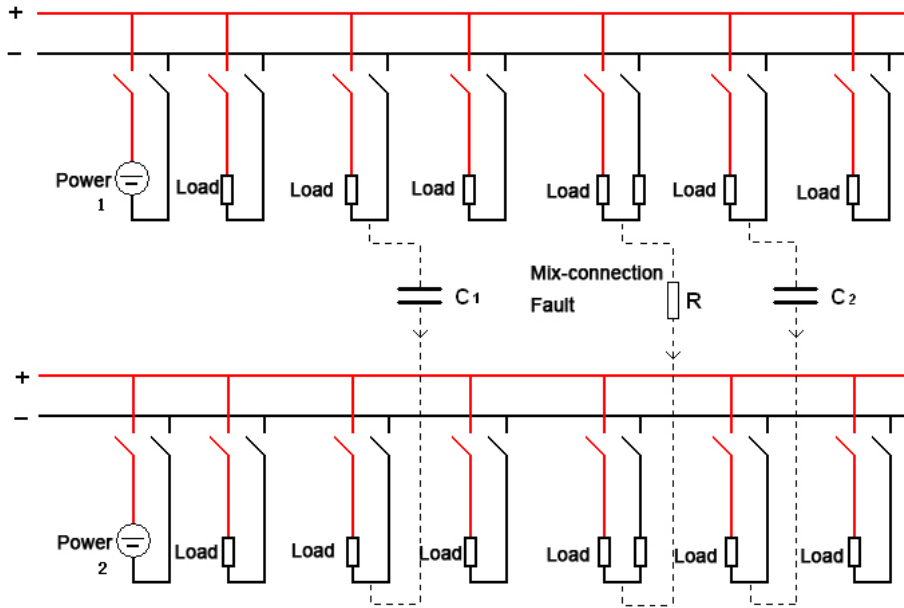

Fig 2.8.1

2.8.2 Short-circuit Fault Location

Short-circuit fault is similar to ground fault location. Signal generator will inject a signal to the circuit and use signal receiver to trace the current signal.

2.9 About Distributed Capacitance

Distributed capacitance is very common phenomenon in DC systems. Generally there is big distributed capacitance when circuit lines are long and wiring structure is complicated in electric circuit. Even if the DC circuit is isolated to the ground, there could be return circuit when signal generator injects current signal due to existence of distributed capacitance. Fig 2.9 is one example. C1 and C2 are distributed capacitance before and after ground fault (R).

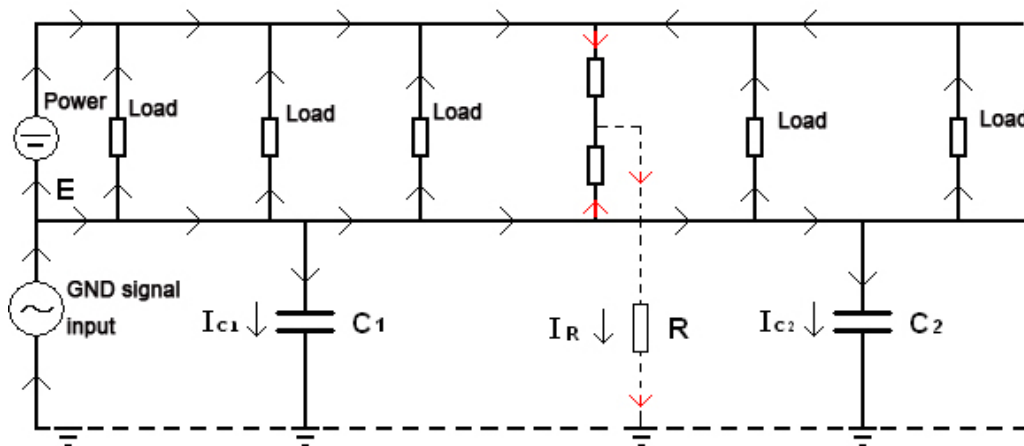

Fig 2.9

In ground fault location, grounding malfunction that we mention is for resistance grounding malfunction. Grounding caused by distributed capacitance, which is objective fact, is not what we concern. But we have to know its existence and affection.

Equivalent resistance of distributed capacitance is:

$$f = \frac{1}{2 \pi RC}$$

f: recommended grounding location frequency (unit: Hz);

R: Grounding resistance (unit: Ω);

C: Distributed capacitance in the circuit (unit: F)

In actual detection of grounding malfunction, the circuit has grounding resistance and distributed capacitance. Distributed capacitance current and resistance current have 90° difference for phase angle. Current signal in the circuit is composed of distributed capacitance current and resistance current. Their directions are as below:

Resistance current: Flow from signal generator output terminal (testing lead) to DC circuit and finally out flow from the grounding point.

Distributed capacitance current: Flow from signal generator output terminal (testing lead) to DC circuit and finally out flow to the earth from different points of circuit in the way of distributed capacitance current.

3. OTHER SETTINGS OF GENERATOR AND RECEIVER

3.1 Signal Generator Setting

3.1.1 Set Date & Time

Select "Time" in main menu, you will see the screen as below. Please use arrow keys to change date and clock. Then click **Save** to confirm the change.

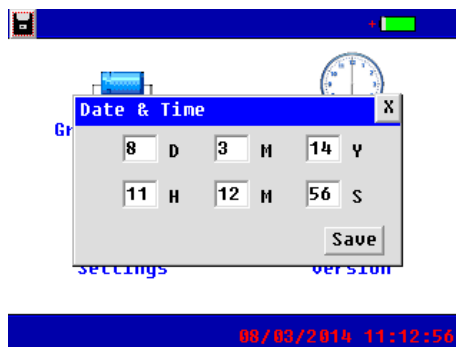

Fig 3.1.1

3.1.2 Parameter Setting

This enables users to select the program between basic version and professional version. To simplify the operation, default setting of all PITE3836 units is basic version with working frequency of 10Hz. In professional version, users can have different selection for output frequency.

Note: Once you change the output frequency in the signal generator, please make sure to do frequency synchronization in signal receiver as per "3.2.3.1 Frequency synchronization".

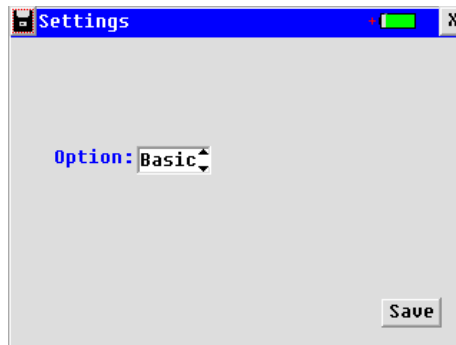

Fig 3.1.2

3.1.3 Firmware Version

Select "Version" in main menu, you will see firmware version of signal generator like below. PITE continuously updates its software and firmware to make it easier to follow and more user-friendly. To get the latest update, you could log in our website to download at <http://www.pitetech.com/Downlist.htm>.

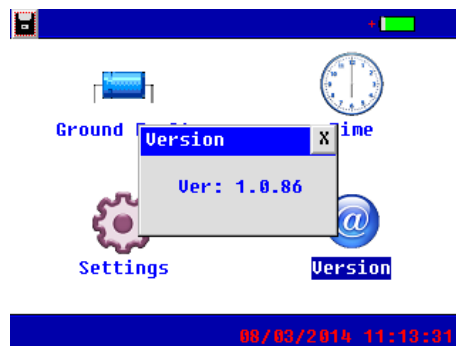

Fig 3.1.3

Update steps:

To update firmware of signal generator, please follow the steps as below:

- 1) Copy the two files (named "Program.hex" and "SCRIPT00.txt" supplied by PITE) to the root directory of PITE USB drive.
- 2) Connect the USB drive with signal generator and restart the unit.
- 3) Firmware update will be done in around one minute.

Note: If you already have the updated files for signal receiver, please first delete them from the root directory.

3.2 Signal Receiver Functions and Settings

3.2.1 Frequency Spectrum Analysis

Standard signal receiver of PITE3836 has frequency spectrum analyzing function to test surrounding frequencies. By testing different frequencies and their strength in the surrounding environment, it will be very helpful for users to avoid interference signals and select the right output frequency for ground fault location.

Connect the current detector with signal receiver, select "Fre Spectrum" in the menu for frequency spectrum analysis:



Fig 3.2.1.1

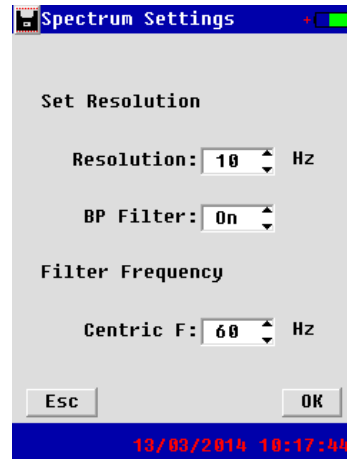

Fig 3.2.1.2

Spectrum resolution is selected among 0.5 Hz, 1 Hz, 5 Hz, 10 Hz and 25 Hz. Different resolutions have different related fineness and maximal frequencies. This will be reflected in the screen (Fig 3.2.1.3) when the current detector is near the tested circuit.

Below is their relationship:

| resolution(Hz) | Frequency spectrum fineness(Hz) | Frequency spectrum analyzing max frequency (Hz) |
|----------------|---------------------------------|---|
| 0.5 | 0.5 | 50 |
| 1 | 1 | 100 |
| 5 | 5 | 500 |
| 10 | 10 | 1000 |
| 25 | 25 | 2500 |

About band pass (BP) filter:

It is built in the signal receiver to enhance the capability of anti-interference.

When BP filter is turned on, the receiver will only sense the centric frequency or frequencies nearby.

For example, in Fig 3.2.1.3, centric frequency is set as 50Hz, it can only sense 50Hz and other comparatively strong signals nearby like 30Hz and 70Hz (resolution is 5Hz).

When BP filter is turned off, it will also sense other frequencies with stronger signal.

For example, in Fig 3.2.1.4, centric frequency is set as 50Hz, it can also sense other stronger signals like 10Hz, 30Hz, 90Hz and so on(resolution is 5Hz).

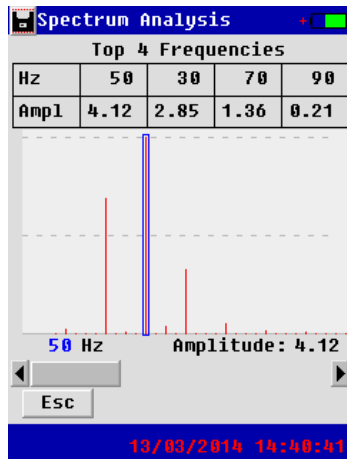

Fig 3.2.1.3 BP filter is ON

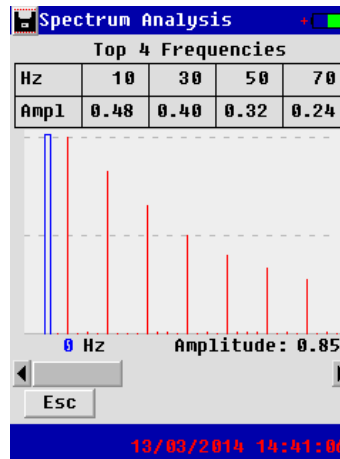

Fig 3.2.1.4 BP filter is OFF

Note: In ground fault location described in Section “2.5 Signal Tracing with Signal Receiver”, the band pass filter is turned on so that signal receiver can bypass other interference signals and only sense the strongest signal (10Hz) which is injected from the signal generator.

3.2.2 Oscilloscope

This is to measure the waveform of target circuit. Please click “Oscilloscope” in main menu, screen will be like:

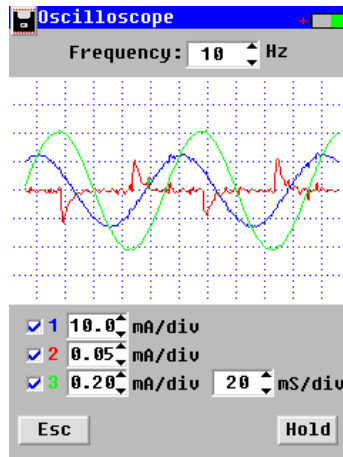

Fig 3.2.2

Screen introduction:

Frequency: Means receiver frequency. It is defaulted as 10Hz.

Channel: Channel 1 in blue indicates the waveform when BP filter is ON. Channel 2 in red indicates the waveform when BP filter is OFF. Channel 3 in green indicates the waveform of synchronization signal.

ms/div: Indicates the time (ms) of each grid in horizontal axle. It is selectable for different view.

mA/div: Indicates current value (mA) of each grid in vertical axle. It is also selectable.

3.2.3 System Setting

Click “System” in main menu, you will see the screen for system setting as below:

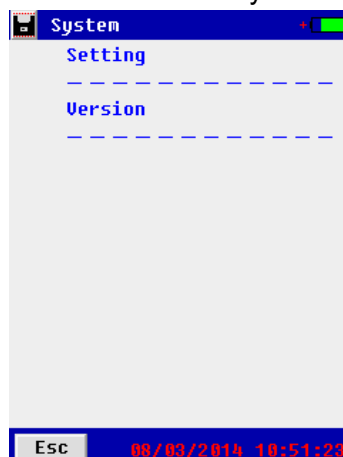

Fig 3.2.3

3.2.3.1 Frequency synchronization

This is to make the receiving frequency of signal receiver identical with output frequency from signal generator. All PITE3836 units are defaulted as 10Hz output frequency and have been synchronized well with signal receiver before delivery to our customers.

If you have different frequency in your signal receiver, you could do frequency synchronization as below:

- 1) Preheat signal generator and signal receiver for at least 20 minutes.
- 2) Change the program version to “Pro Version” in Section “3.1.2 Parameter Setting”.
- 3) Connect the two signal testing leads with signal generator and connect the other two ends of leads with resistor of around 10k ohm.
- 4) Output voltage of signal generator is set as 48V. DO NOT set it too high. Select the output frequency, and go to the screen like below in signal generator.

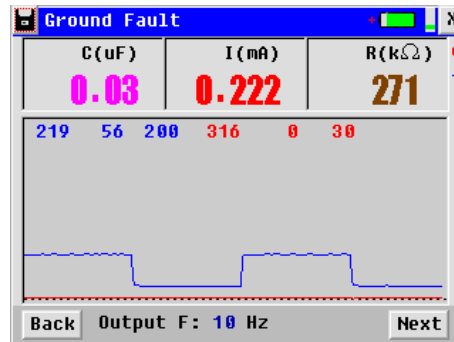

Fig 3.2.3.1

- 5) Clamp one current detector of signal receiver around output terminal (red testing lead like Fig 3.2.3.1.1) and keep it still for a while.
- 6) Go to “System”→“Setting”→“Freq Synchronization” in signal receiver. Select the same frequency as that of signal generator and click the button **F Sync** in the screen below (Fig 3.2.3.1.2 and Fig 3.2.3.1.3). Frequency synchronization will be done and saved in 236 seconds.

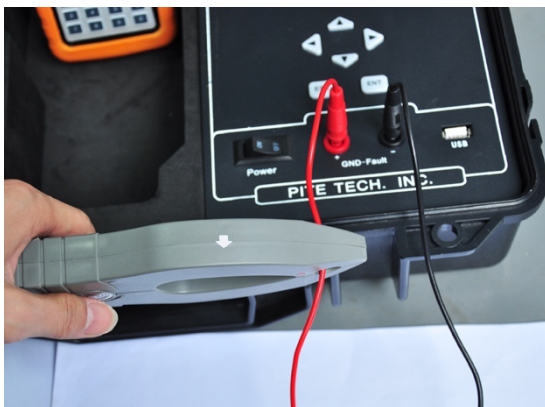

Fig 3.2.3.1.1

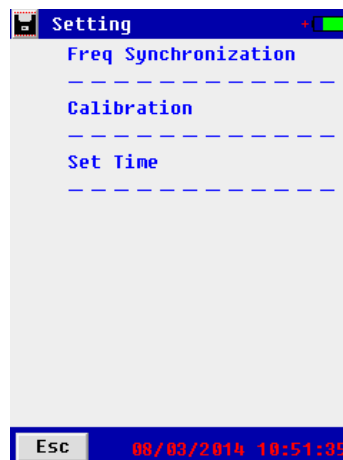

Fig 3.2.3.1.2

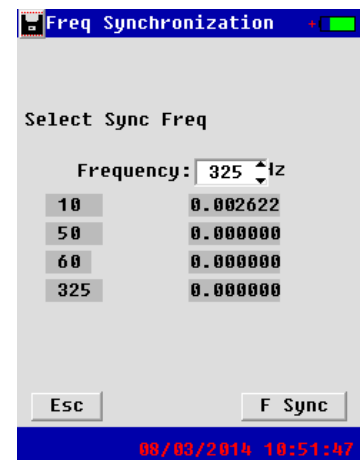

Fig 3.2.3.1.3

3.2.3.2 Signal Receiver Calibration

All units are well calibrated in PITE’s lab before they leave for our customers’. Generally it is no need to calibrate again. Upon big accuracy errors and calibration is needed. Please contact PITE to get separate calibration manual.

3.2.3.3 Signal Receiver Time Setting

Go to “System”→“Setting” → “Set Time” in the menu, change the time if necessary click **OK** to save the change.

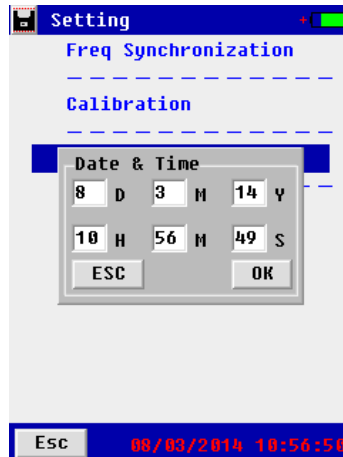

Fig 3.2.3.3

3.2.3.5 Firmware version and update

Select “Version” in main menu, you will see firmware version of signal receiver like below.

The update procedure is same as that of signal generator.

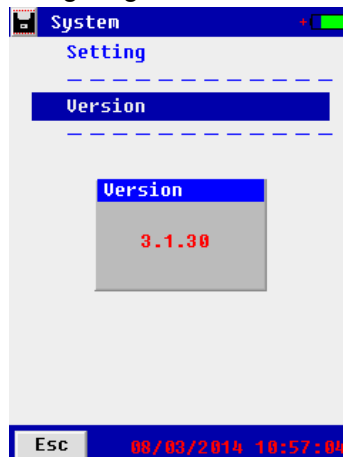

Fig 3.2.3.5

Note: If you already have the updated files for signal generator, please first delete them from the root directory of PITE USB to avoid any conflict.

4. MAINTENANCE

4.1 FAQ

| Item | Description | Causes | Solutions |
|------|--|---|---|
| 1 | Signal strength and phase angle in signal receiver sometimes is high sometimes low | 1. Signal display of signal generator is set as “Discontinue” mode. | Change it to “Continue” mode. |
| | | 2. Signal is too weak | Increase the output voltage somehow |
| | | 3. There might be similar frequencies around that interferes the signal | Use frequency spectrum analyzing function of signal receiver to test surrounding signals and select the right output frequency. |
| | | 4. Opening jaw of current detector is closed or the jaw has dirt. | Close the jaw of current detector and clean the clamp jaw. |

| | | | |
|---|--|--|--|
| | | 5. Reference value is set when it does not clamp in the circuit that has current flow. | Clamp the current detector in the circuit and make sure that the signal generator is transmitting signal properly, then set the reference point. |
| 2 | In the same point, signal receiver shows steady signal strength but phase angle is increased or decreased in certain rate. | 1. Frequency synchronization is not done in the signal receiver. 2. Current detector is not kept stable during frequency synchronization. | Redo "Frequency synchronization" with current detector clamped on red testing lead. |
| 3 | Relay maloperation during ground fault location | Red test lead is incorrectly connected with busbar that has normal insulation. | Connect it in the right busbar |
| 4 | Equipment works for short time. Battery power off pretty soon. | Not fully powered before operation | 1. Fully charge the signal generator and receiver before using. 2. For long time operation, please connect power adaptor with signal generator. |
| 5 | Not sure whether signal generator or receiver can work normally or not. | | Please do as per "4.1 Self-Check". |
| 6 | Screen has no display after power-on | | Please check if input power lead is well connected or not. |
| 7 | Keypad invalid or has wrong operation | | Please check if keypads are stuck in the panel or not. If so, make them pop up. |

4.2 Cleaning & Storage

4.2.1 Cleaning

Clean PITE3836 main unit and its accessories with soft damp cloth and a mild cleaner. Do not use abrasives, solvents, or alcohol, as they can deform or discolor the Locator and the accessories.

After cleaning voltage testing clip with software cloth, clean it again with water and wipe it. Do not damage the metal part of the clips to ensure its accurate performance during testing.

 **WARNING:** For your own safety, make sure that the main unit and accessories are not working and should be disconnected from the power supply before cleaning.

4.2.2 Storage

After using PITE3836, put the main unit and all its accessories into the carrying case, store the case in ventilating place under proper temperature and humidity. Never expose the equipment and its accessories to water, high humidity, or dampness. If not used for some time, the Li-battery will discharge itself gradually. To keep its best performance, you are suggested to charge the battery periodically, like once a month.

5. CONTACT PITE

PITE TECH. INC.

2/F, Bldg E, Chiwan Industrial Park, Shaodi Rd., Chiwan, Shekou Area, Shenzhen, China

sales@pitetech.com

www.pitetech.com